

Ball Screw



1-1 Features of TBI MOTION Ball Screw	C02
1-2 Ball Screw Selection Procedure	C04
1-3 Accuracy	C05
1-4 Screw Shaft Design.....	C11
1-5 Driving Torque	C17
1-6 Nut Design.....	C19
1-7 Rigidity	C21
1-8 Positioning Accuracy.....	C24
1-9 Service Life Design	C26
1-10 Cautions About Use of Ball Screws	C32
2-1 Nominal Model Code of Ball Screw	C36
2-2 Precision Ground Ball Screw Series.....	C39
2-2-1 TBI MOTION Nut of Precision Ground Ball Screw Type.....	C39
2-3 Rolled Ball Screw	C64
2-3-1 Rolled Screws	C64
2-3-2 The Features of TBI MOTION Rolled Ball Screw.....	C64
2-3-3 Nominal Model Code of Rolled Ball Screws	C64
2-3-4 Preload of Rolled Ball Screw	C67
2-4 Rolled Ball Screw Series.....	C68
2-4-1 TBI MOTION Nut of Rolled Ball Screw Type	C68
2-5 Ball Screw Weight List.....	C85

ABOUT BALL SCREW

1-1 Features of *TBI MOTION* Ball Screw

(1) High Reliability

TBI MOTION applies stringent quality control standards on every production process. With proper lubrication and use, trouble-free operation for an extended period of time is possible.

(2) Smooth Operation

The high efficiency of ball screw is vastly superior than conventional screws as shown in Fig 1.1.1. It takes less than 30% torque to make the linear motion into rotary motion.

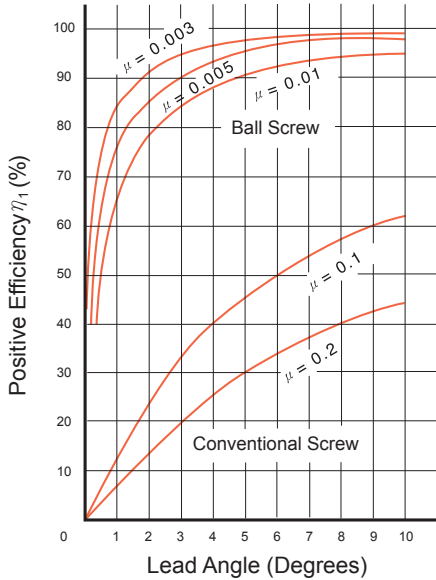

Normal usage (to convert rotary motion to linear motion)

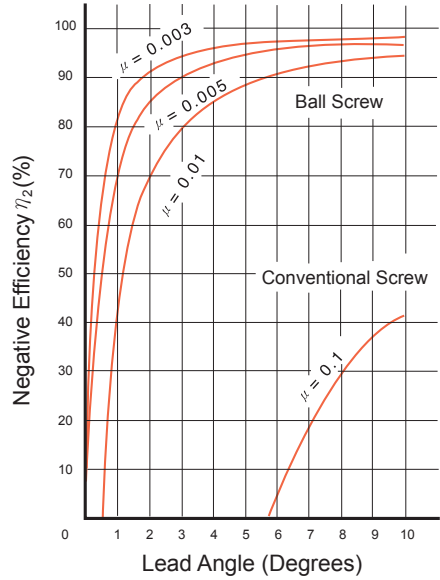

Special usage (to convert linear motion to rotary motion)

μ : Friction Coefficient (Ground Ball Screw $\mu=0.005$, Rolled Ball Screw $\mu=0.01$)

$$P = \frac{2\pi\eta_1 \times T}{\ell}$$

T = Torque kgf · cm
P = Force kgf
 ℓ = Lead cm
 η_1 = Efficiency

$$T = \frac{\ell \times \eta_2 \times P}{2\pi}$$

T = Torque kgf · cm
P = Force kgf
 ℓ = Lead cm
 η_2 = Efficiency

Fig 1.1.1 Mechanical Efficiency of Ball Screws

(3) High Rigidity and Preload

As figure 1.1.2 shown in below, the ball screw of TBI MOTION is designed with Gothic arch groove, which makes the screw easy to rotate even using minimum axial play. To make the rigidity more appropriate to using condition, you can change the preload between one or two screw nuts to reduce axial play.



Fig 1.1.2 Groove Shape of *TBI MOTION* Precision Ball Screw

(4) Circulation Method

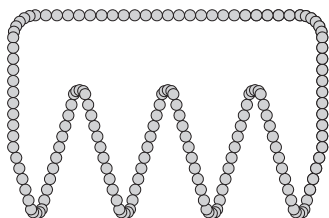

Fig 1.1.3 External Ball Circulation Nuts

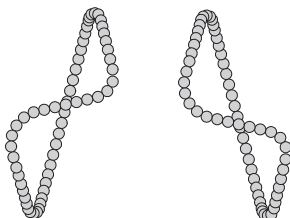

Fig 1.1.4 Internal Ball Circulation Nuts

(5) High Durability

TBI MOTION Rigidly selected materials, intensive heat treating and processing techniques, backed by years of experience, have resulted in the most durable ball screws manufactured. (See Table1.1.1 & Fig1.1.5)

Table 1.1.1 Material and Heat Treatment

Item	Material	Hardness
Screw	High-Carbon Steel Chrome Molybdenum Steel	HRC 58°~64°
Nut	Chrome Molybdenum Steel	HRC 58°~62°
Steel Ball	Chrome Molybdenum Steel	HRC 62°UP

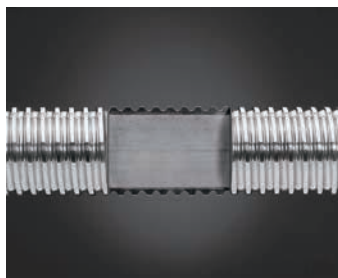
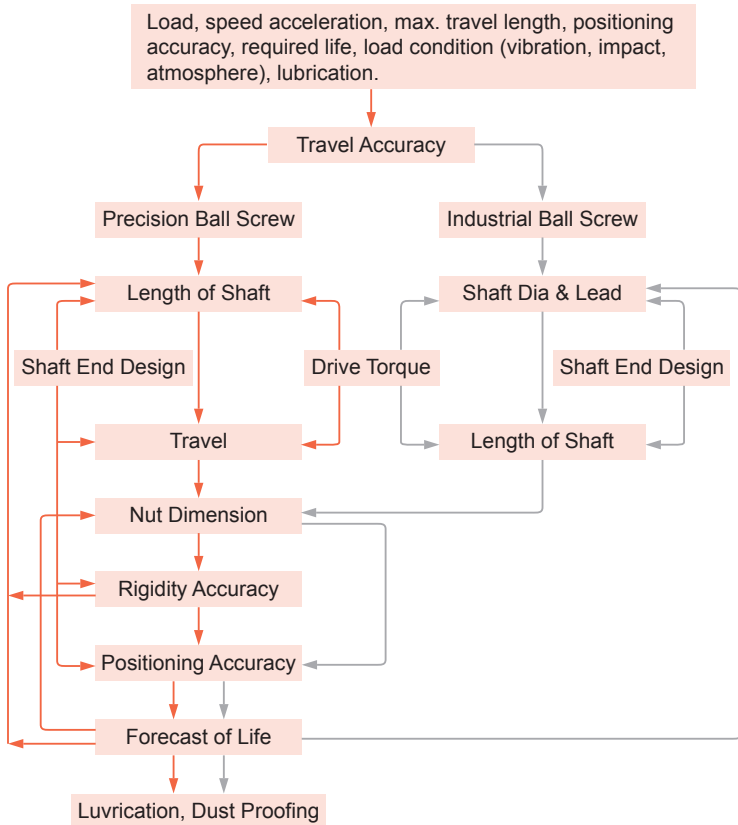

Fig 1.1.5 Heat Treatment

ABOUT BALL SCREW

1-2 Ball Screw Selection Procedure



Accuracy (C05)
Screw Shaft Design (C11)
Drive Torque (C17)
Nut Design (C19)

Rigidity (C21)
Positioning Accuracy (C24)
Life Design (C26)
Lubrication and safety design (C32)

1-3 Accuracy

1-3-1 Lead/Travel Accuracy

According to the standard of JIS, we classified our lead accuracy through E, e, e₃₀₀ and e_{2π}, four main regulations. As figure 1.3.1 ~ 1.3.3 shown in below, all the definition and tolerance are specified. To test the accumulated travel deviations for grade C7 and C10, the tolerance will be chosen in random 300mm of useful length and evaluated if it is qualified with the e₃₀₀ table of 1.3.3.

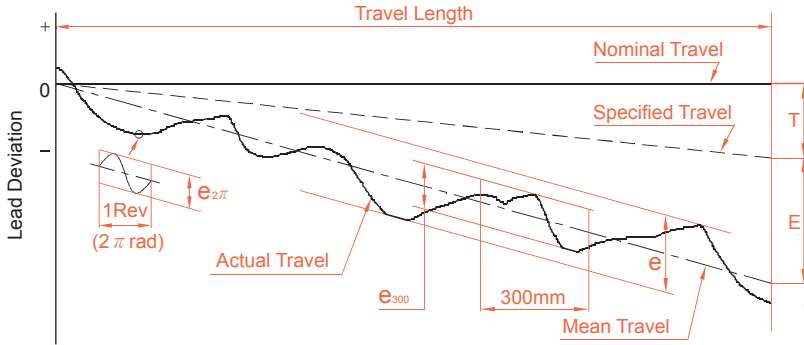

Fig 1.3.1 Diagram of Lead Accuracy

Terms	Reference	Definition	Allowable
Travel Compensation	T	Travel compensation is the deduction between specified and nominal travel in the useful travel. A slightly smaller value compared with nominal travel is often selected by customer, to compensate for an expected elongation caused by temperature rise or external load. Therefore " T " is usually a negative value. <i>Note : if no compensation is needed, specified travel is the same as nominal travel.</i>	
Actual Travel		Actual travel is the axial displacement of the nut relative to the screw shaft.	
Mean Travel		Mean travel is the linear best fit line of actual. This could be obtained by the least squares method. This line represents the tendency of actual travel.	
Mean Travel Deviation	E	Mean travel deviation is the deduction between mean travel and specified travel within travel length.	Table 1.3.2
Travel Variations	e	Travel variations is the coverage of 2 lines drawn parallel to the mean travel.	Table 1.3.2
	e ₃₀₀	Maximum width of variation within the travel length.	Table 1.3.3
	e _{2π}	Actual width of variation for the length of 300mm taken anywhere within the travel length. Wobble error, actual width of variation for one revolution (2π radian)	Table 1.3.3

ABOUT BALL SCREW

1-3 Accuracy

Table 1.3.2 Mean Travel Deviation ($\pm E$) and Travel Variation (e) (JIS B 1192)

Unit : μm

Grade		C0		C1		C2		C3		C5		C7	C10	
Travel Length (mm)	Over	Incl.	$\pm E$	e	$\pm E$	e	$\pm E$	e	$\pm E$	e	$\pm E$	e	e	
		100	3	3	3.5	5	5	7	8	8	18	18	$\pm 50/300\text{mm}$	$\pm 210/300\text{mm}$
	100	200	3.5	3	4.5	5	7	7	10	8	20	18		
	200	315	4	3.5	6	5	8	7	12	8	23	18		
	315	400	5	3.5	7	5	9	7	13	10	25	20		
	400	500	6	4	8	5	10	7	15	10	27	20		
	500	630	6	4	9	6	11	8	16	12	30	23		
	630	800	7	5	10	7	13	9	18	13	35	25		
	800	1000	8	6	11	8	15	10	21	15	40	27		
	1000	1250	9	6	13	9	18	11	24	16	46	30		
	1250	1600	11	7	15	10	21	13	29	18	54	35		
	1600	2000			18	11	25	15	35	21	65	40		
	2000	2500			22	13	30	18	41	24	77	46		
	2500	3150			26	15	36	21	50	29	93	54		
	3150	4000			30	18	44	25	60	35	115	65		
	4000	5000					52	30	72	41	140	77		
	5000	6300					65	36	90	50	170	93		
	6300	8000							110	60	210	115		
	8000	10000									260	140		
	10000	12500									320	170		

Table 1.3.3 International standard of accuracy grade for ball screw

Unit : μm

Grade		Ground					Ground		
		C0	C1	C2	C3	C5	Rolled		
e_{300}	ISO, DIN	-	6	-	12	23	23	52	210
	JIS	3.5	5	-	8	18	18	50	210
	TBI MOTION	3.5	5	7	8	18	23	50	210

1-3-2 Axial Play

Axial play of **TBI MOTION's** precision ball screw is shown below:

Table 1.3.4 Classification of Axial Play

Grade	P0	P1	P2	P3	P4
Axial Play	Yes	No	No	No	No
Preload	No	No	Light	Medium	Heavy

Excessive preload increases the friction torque and generates heat which will reduce the life expectancy. However, insufficient preload will reduce stiffness and increase the possibility of lost motion. **TBI MOTION** recommends that the preload applied on CNC machine tools should not heavier than 8% of the dynamic load; 5% for industrial automation X-Y table.

Table 1.3.5 The reference spring force of (P2)

Model No.	Spring Force (Kg) Single Nut	Spring Force(Kg) Double Nut
1605	0.1~0.3	0.3~0.6
2005	0.1~0.3	0.3~0.6
2505	0.2~0.5	0.3~0.6
3205	0.2~0.5	0.5~0.8
4005	0.2~0.5	0.5~0.8
2510	0.2~0.5	0.5~0.8
3210	0.3~0.6	0.5~0.8
4010	0.3~0.6	0.5~0.8
5010	0.3~0.6	0.8~1.2
6310	0.6~1.0	0.8~1.2
8010	0.6~1.0	0.8~1.2

Table 1.3.6 Axial Play (P0) Clearance in the Axial Direction of Rolled and Ground Ball Screw Unit : mm

Nominal Diameter	Rolled Ball Screw Clearance in the Axial Direction (max.)	Ground Ball Screw Clearance in the Axial Direction (max.)
Ø04~Ø14 miniature ball screw	0.05	0.015
Ø15~Ø40 middle size of ball screw	0.08	0.025
Ø50~Ø100 big size of ball screw	0.12	0.05

ABOUT BALL SCREW

1-3 Accuracy

■ 1-3-3 Definition of Mounting Accuracy and Tolerance on Ball Screw

The main items of the mounting accuracy of ball screw are listed in below.

- (1) Periphery run-out of the supporting part of the screw shaft to the screw groove.
- (2) Concentricity of a mounting portion of the shaft to the adjacent ground portion of the screw shaft.
- (3) Perpendicularity of the shoulders to the adjacent ground portion of the screw shaft.
- (4) Perpendicularity of the nut flange to the axis of the screw shaft.
- (5) Concentricity of the ball nut diameter to the screw groove.
- (6) Parallelism of the mounting surface of a ball nut to the screw groove.
- (7) Total run-out of the screw shaft to the axis of the screw shaft.

All **TBI MOTION** ball screws are manufactured, inspected and guaranteed to be within specifications.

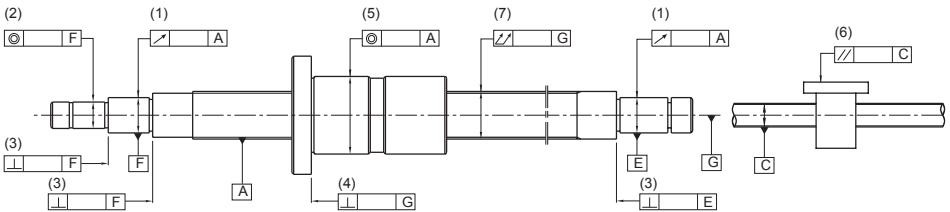

Fig 1.3.2 Mounting Accuracy and Tolerance

■ 1-3-4 Preload Torque

As figure 1.3.3 shown in below, it specified all the type of preload torque generated by rotating a preloaded ball screw.

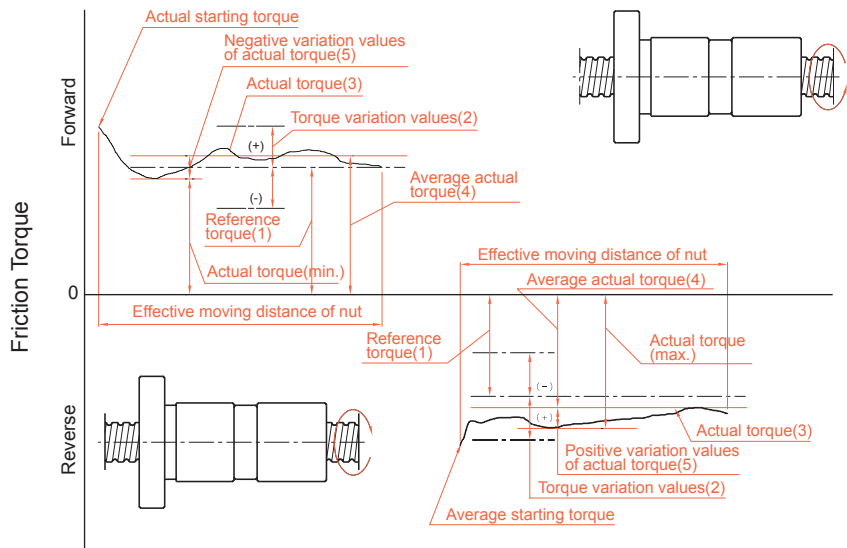

Fig 1.3.3 Descriptions of preload torque

Glossary

(1) Preload

To generate the inner force inside the ball screw to decrease the clearance and increase the rigidity, a set of one gage (approximately 2μ) larger steel balls is filled inside the nut or two nuts which are executing mutual displacement in axial direction.

(2) Preload dynamic torque

The dynamic torque required for continuously rotating the screws shaft or the nuts under unload condition and the preload has applied to the ball screws.

(3) Reference torque

The targeted preload dynamic torque Fig 1.3.3-(1)

(4) Torque variation values

The variation values of the targeted preload torque variation rates are specified generally based on JIS standards as indicated in Fig 1.3.3.

(5) Torque variation rate

The variation ratio of reference torque.

(6) Actual torque

The actual measured preload dynamic torque of the ball screws.

(7) Average actual torque

The arithmetic average of the maximal and minimal actual torque values measured when the nuts are doing reciprocating movements.

(8) Actual torque variation values

After the nut doing reciprocating movements on the effective length of the thread, the biggest variation tested will be the actual torque variation value, which is covered between the positive and negative minimum value relative to the actual torque.

(9) Actual torque variation rate

The rate of actual torque variation values in relation of the average actual torque.

ABOUT BALL SCREW

1-3 Accuracy

Table 1.3.7 Permissible ranges of torque variation rates

Reference torque kgf·cm		Effective threading length mm										
		Below 4000								4000~10000		
		Slenderness 1 : below 40				Slenderness 1 : 40~1 : 60				-		
		Grade				Grade				Grade		
Over	Incl	C0	C1	C2, C3	C5	C0	C1	C2, C3	C5	C1	C2, C3	C5
2	4	±35%	±40%	±45%	±55%	±45%	±45%	±55%	±65%	-	-	-
4	6	±25%	±30%	±35%	±45%	±38%	±38%	±45%	±50%	-	-	-
6	10	±20%	±25%	±30%	±35%	±30%	±30%	±35%	±40%	-	±40%	±45%
10	25	±15%	±20%	±25%	±30%	±25%	±25%	±30%	±35%	-	±35%	±40%
25	63	±10%	±15%	±20%	±25%	±20%	±20%	±25%	±30%	-	±30%	±35%
63	100	-	-	±15%	±20%	-	-	±20%	±25%	-	±25%	±30%

Remarks : 1. Slenderness is the value of dividing the screws shaft outside diameter with the screws shaft threading length.
2. For reference torque less than 2 kgf·cm, **TBI MOTION** specifications will apply.

Calculation of Reference Torque T_p

The equation for computing reference torque of the ball screws is given in following :

$$T_p = 0.05 (\tan\beta)^{-0.5} \cdot \frac{F_{a0} \cdot \ell}{2\pi}$$

Where, F_{a0} = Preload (kgf)

β = Lead angle

ℓ = Lead (cm)

Measurement Conditions

The measure condition as indicated in Fig 1.3.4, the preload dynamic torque will be the multiplication of F (The force to make the nut stay still during rotating the screw) and L (The arm of force).

$$T_p = F \cdot L$$

Measure conditions

- (1) Measurement is executed under the condition of unattached with scraper.
- (2) The rotating speed during measurement maintains at 100 rpm.
- (3) According to JSK2001(industrial oil viscosity standard), the lubrication oil used should be in compliance with ISO VG68.

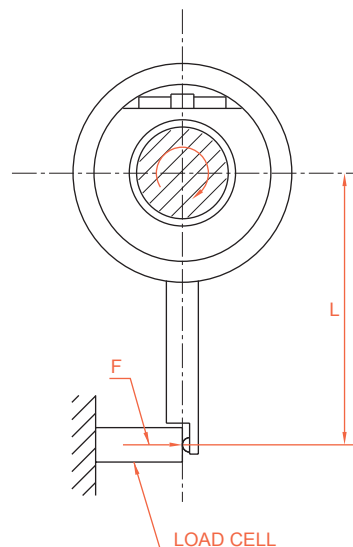

Fig 1.3.4 Preload dynamic torque measuring method

1-4 Screw Shaft Design

■ 1-4-1 Mounting Methods

It's important to consider mounting method (Fig 1.4.1~1.4.8) during your selection of ball screw specification. If you have special requirement related with mounting method, please consult TBI MOTION.

(Mounting Screw and Nut)

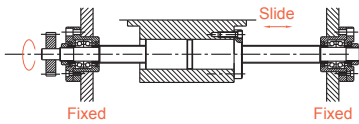

Fig 1.4.1

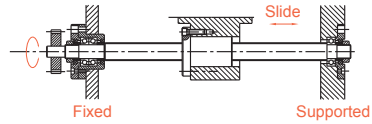

Fig 1.4.5

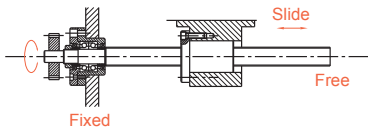

Fig 1.4.2

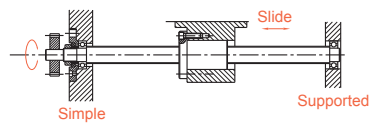

Fig 1.4.6

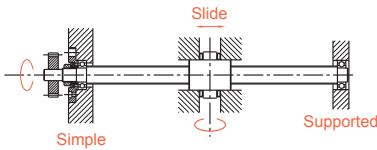

Fig 1.4.3

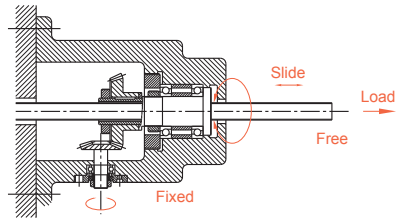

Fig 1.4.7

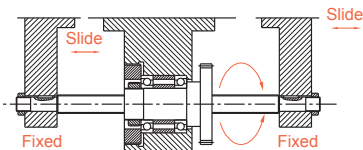

Fig 1.4.4

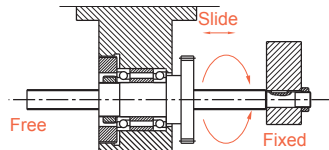

Fig 1.4.8

ABOUT BALL SCREW

1-4 Screw Shaft Design

(The mounting method for common types of machinery.)

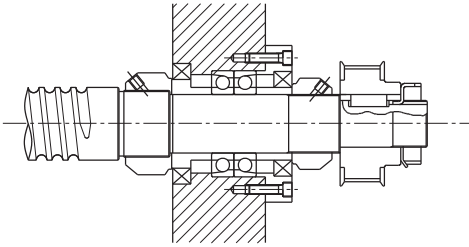

Fig 1.4.9

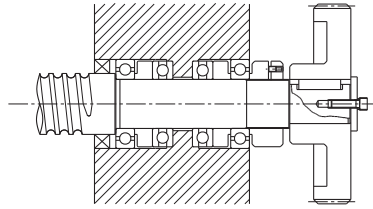

Fig 1.4.11

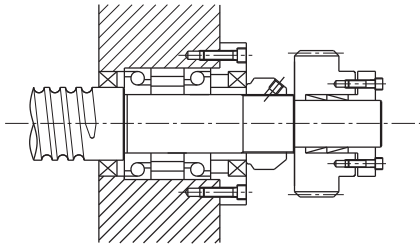

Fig 1.4.10

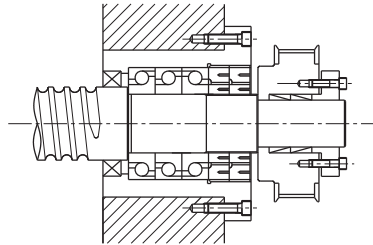

Fig 1.4.12

(The mounting method for bearing in a given pretension.)

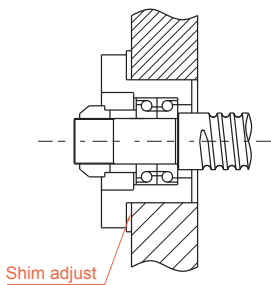

Fig 1.4.13

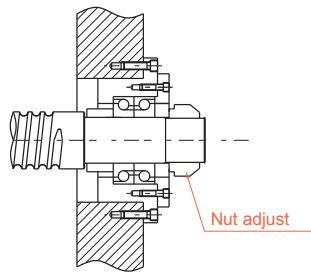

Fig 1.4.14

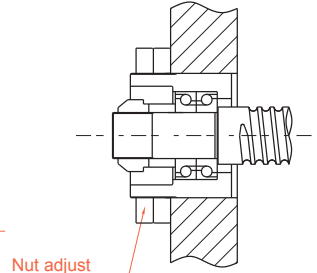

Fig 1.4.15

■ 1-4-2 Allowable Load of Axial Direction

(1) Buckling Load

The safety of the screw shaft against buckling needs to be checked when the shaft is expected to receive buckling loads. Fig 1.4.16 shows a diagram which summarizes the allowable compressive load for buckling for each nominal outside diameter of screw shaft. (Calculate with the equation shown in below when the nominal outside diameter of the screw shaft exceeds 125mm.)

Select the graduation of allowable axial load according to the method of ball screw support method.

$$P = \alpha \cdot \frac{l \cdot N \cdot \pi^2 \cdot E}{l^2} = m \frac{dr^4}{l^2} \cdot 10^3$$

Where

α = Safety Factor ($\alpha = 0.5$)

E : Vertical elastic modules ($E = 2.1 \cdot 10^4 \text{ kgf/mm}^2$)

l : Min. secondary moment of screw shaft sectional area

$$l = \frac{\pi}{64} dr^4 (\text{mm}^4)$$

dr : Screw shaft root diameter (mm)

L : Mounting distance (mm)

m · N : Coefficient determined from mounting method of ball screw

Floated-Floated m = 5.1 (N = 1)

Fixed-Floated m = 10.2 (N = 2)

Fixed-Fixed m = 20.3 (N = 4)

Fixed-Free m = 1.3 (N = 1/4)

(2) Allowable Tensile/Buckling Load

With shorter mounting distance, please calculate the two items describe in below.

1. The allowable tensile / buckling load which equals to the derating stress.

2. Allowable load of the screw's groove.

$$P = \sigma A = 11.8 dr^2 (\text{kgf})$$

Where,

P : Buckling load (kgf)

σ : Allowable tensile compressive stress (kgf/mm^2)

A : Sectional area of screw shaft root bottom diameter (mm^2)

dr : Screw shaft root diameter (mm)

ABOUT BALL SCREW

1-4 Screw Shaft Design

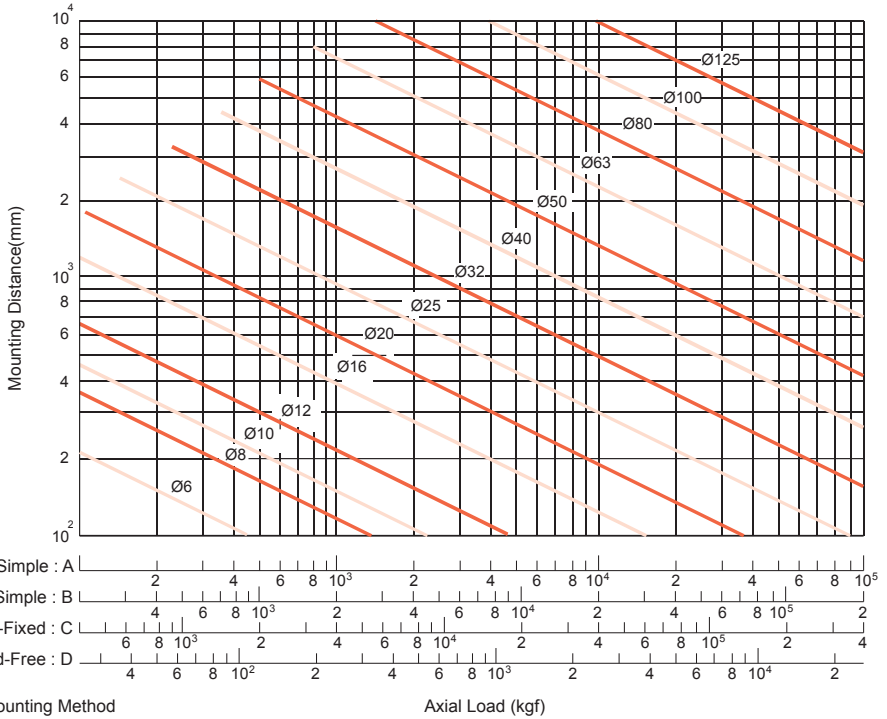

Fig 1.4.16 Buckling Load vs. Nominal Diameter and Length

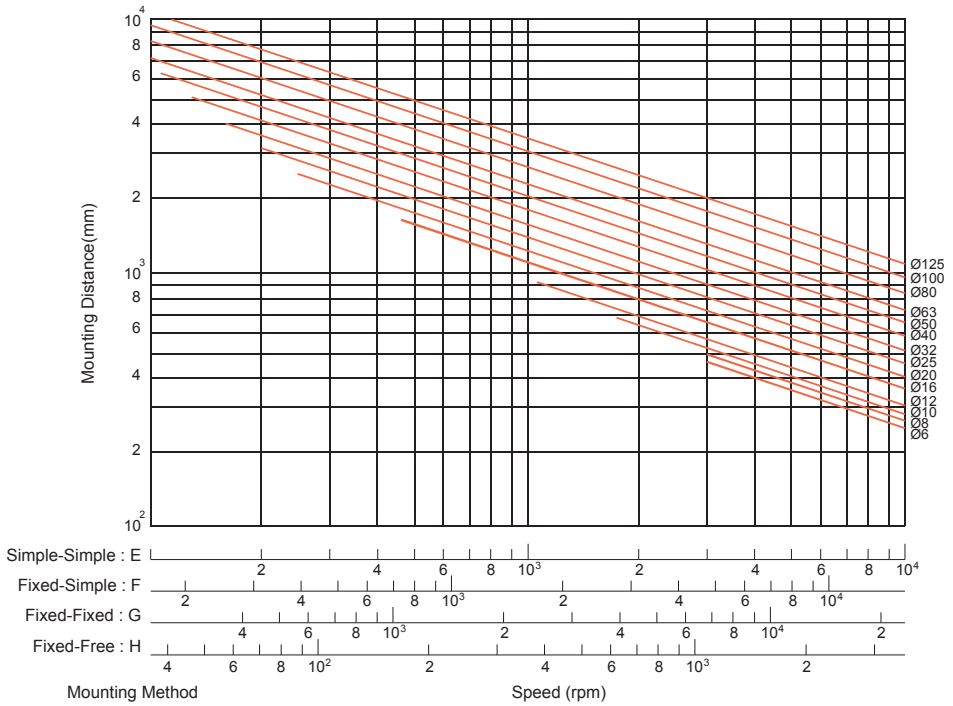

Fig 1.4.17 Critical Speed vs. Nominal Diameter

ABOUT BALL SCREW

1-4 Screw Shaft Design

■ 1-4-3 Critical Speed

(1) Dangerous speed

To prevent the screw's natural frequency attain resonance which will occur critical speed, it's necessary to look into the ball screw allowable rotation speed (Below 80% of the Critical Speed). More detail of allowable rotation speed classified though screw diameter please refer to Fig 1.4.17.

(2) $D_m \cdot n$ value

The allowable rotation speed is regulated also by the $D_m \times N$ value (D_m : diameter of central circle of steel ball, N : Revolution speed, rpm) which expresses the peripheral speed.

Generally,

For precision

(Ground shaft C7 to C0)
 $D_m \times N \leq 70,000$

For general industry (Rolled shaft)
 $D_m \times N \leq 50,000$

If your requirement about the product will exceed the limitation, please contact with TBI MOTION to discuss the detailed solution for the ideal product.

※ When ϵ , the ratio of screw length and shaft diameter has exceeded 70, please contact with TBIMOTION to arrange the special arrangement for production.

$$n = \alpha \cdot \frac{60\lambda^2}{2\pi L^2} \sqrt{\frac{Eg}{\gamma A}} = f \frac{dr}{L^2} \cdot 10^7(\text{rpm})$$

Where

α : Safty factor ($\alpha = 0.8$)

E : Verticle elastic modules ($E = 2.1 \cdot 10^4 \text{kgf/mm}^2$)

l : Minimum secondary torque of axial section plane

$$l = \frac{\pi}{64} dr^4(\text{mm}^4)$$

dr : Screw shaft root diameter (mm)

g : Acceleration of gravity ($g = 9.8 \cdot 10^3 \text{mm/s}^2$)

γ : Density ($\gamma = 7.8 \cdot 10^6 \text{kgf/mm}^3$)

A : Screw shaft sectional area ($A = \pi dr^2/4 \text{mm}^2$)

L : Mounting distance (mm)

f, λ : Coefficient determined from the ball screw mounting method

Floated-Floated $f = 9.7$ ($\lambda = \pi$)

Fixed-Floated $f = 15.1$ ($\lambda = 3.927$)

Fixed-Fixed $f = 21.9$ ($\lambda = 4.730$)

Fixed-Free $f = 3.4$ ($\lambda = 1.875$)

1-5 Driving Torque

■ 1-5-1 Driving torque Ts of the transmission shaft

$T_S = T_P + T_D + T_F$ (in fixed speed)

$T_S = T_G + T_P + T_D + T_F$ (when accelerating)

T_G : Acceleration torque (1) T_P : Load torque (2)

T_D : Preload torque (3) T_F : Friction torque (4)

(1) Acceleration T_G

$$T_G = J\alpha \text{ (kgf} \cdot \text{cm)}$$

$$\alpha = \frac{2\pi n}{60\Delta t} \text{ (rad/s}^2\text{)}$$

J : Moment of inertia (kgf · cm · s²)

α : Angular acceleration (rad/s²)

n : Revolutions (min⁻¹)

Δt : Starting time (sec)

(3) Preload torque T_D

$$T_D = \frac{K \cdot P_{PL} \cdot \ell}{\sqrt{\tan \alpha} \cdot 2\pi} \text{ (kgf} \cdot \text{cm)}$$

K : Internal coefficient

(0.05 is usually adopted)

P_{PL} : Preload (kgf)

ℓ : Lead (cm)

α : Lead angle

(4) Friction torque T_F

$$T_F = T_B + T_O + T_I \text{ (kgf} \cdot \text{cm)}$$

T_B : Friction torque of bracing shaft

T_O : Friction torque of free shaft

T_I : Friction torque motor shaft

(2) Lead torque T_P

$$T_P = \frac{P \cdot \ell}{2\pi\eta_1} \text{ (kgf} \cdot \text{cm)}$$

$P = F + \mu Mg$

P : Axial load (kgf)

ℓ : Lead (cm)

η_1 : Positive efficiency

The efficiency when rotating motion is altered to linear motion

F : Cutting force (kgf)

μ : Friction

M : Mass of moving object (kg)

g : Acceleration of gravity (9.8 m/s²)

$$T_P = \frac{P \cdot \ell \cdot \eta_2}{2\pi} \text{ (kgf} \cdot \text{cm)}$$

η_2 : Reverse efficiency

The efficiency when linear motion returns to rotating motion

The friction torque of the bracing shaft would be affected by the volume of lubrication oil. Besides, be careful with the excessive tight end seal may lead to unexpected over friction torque or temperature rise.

【For reference】 Moment of inertia of load (refer to Table 1.5.1)

$$J = J_{BS} + J_{CU} + J_W + J_M$$

J_{BS} : Moment of inertia Ball screws shaft

J_{CU} : Moment of inertia Coupler

J_W : Moment of inertia Linear motion part

J_M : Moment of inertia Roller shaft part of motor shaft

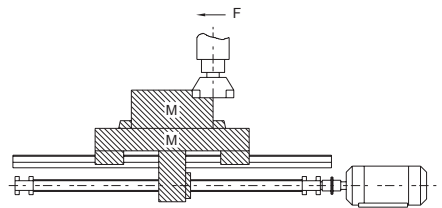

Fig 1.5.1 Moment of inertia of load

ABOUT BALL SCREW

1-5 Driving Torque

Table1.5.1 Conversion formula for moment of inertia of load

Formula	J
Moment of inertia converted from motor shaft	
Cylinder load	$\frac{\pi \rho L D^4}{32}$
Linearly moving object	$\frac{M}{4} \left(\frac{V \ell}{\pi \cdot N_M} \right)^2 = \frac{M}{4} \left(\frac{P}{\pi} \right)^2$
Unit	kg · m ²
Moment of inertia during deceleration	$J_M = \left(\frac{J_\ell}{N_M} \right)^2 J \ell$

ρ : Density (kg/m³) $\rho = 7.8 \cdot 10^3$

L : Cylinder length (m)

D : Cylinder diameter(m)

M : Mass of the linear motion part (kg)

V : Velocity of the linear moving object (m/min)

N_M : Motor shaft revolutions (min⁻¹)

P : The moving magnitude of the linearly moving object per rotation of the motor (m)

N ℓ : Rotations in longitudinal moving direction (min⁻¹)

J ℓ : Moment of inertia in load direction

J_M : Moment of inertia in motor direction

■ 1-6-1 Selection of Nut

(1) Series

When making selection of series, please take demanded accuracy, intended delivery time, dimensions(the outside diameter of screw, ratio of lead/ the outside diameter of screw) preload and etc into consideration.

(2) Circulation type

Selection of circulation type : Please consider the efficiency of screw nut's mounting space. The advantage of each circulation type will be specified in figure 1.6.1.

(3) Number of loop circuits

Performance and service life should be considered when selecting number of loop circuits.

(4) Shape of flanges (FLANGE)

Please make selection based on the available space for the installation of nuts.

(5) Oil hole

Oil holes are provided for the precision ball screws, please use them during machine assembling and regular furnishing.

1-6 Nut Design

Table 1.6.1 Circulation type

Circulation type	Model		Characteristic
	Single Nut	Double Nuts	
Internal circulation type	SFM SFNI SFK SFNU BSH	OFU OFI	<ul style="list-style-type: none"> • Delicated diameter of screw takes only little space. • Applicable to those with smaller lead / the outside diameter of the screw
External circulation type	SFV XSV BSH	OFV	<ul style="list-style-type: none"> • Economy • Applicable to larger lead and diameter. • Applicable for high loading purpose. (TBI MOTION patent nut)
End-caps circulation type	SFY SFH SFJ SFA SFYA		<ul style="list-style-type: none"> • Suitable for high speed positioning

1-6-2 Nut Types

U, I, M - Type Nut

In these types of nuts, by using the internal circulator which makes the ball pass over the crest diagonally, the ball will return to the starting point. Normally, one roll of balls will fit with one circulation. As figure 1.6.1 specified, these types of nuts need at least one side which is completely threading, which is applicable for smaller shaft diameter.

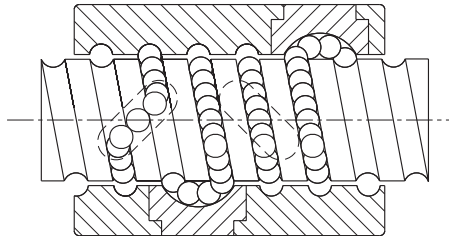

Fig 1.6.1 U, I, M - Type Nut

K - Type Nut

It applies the similar circulation as that of I-type, but circulation takes place in key slots of identical angle for different circulation. (see Fig 1.6.2)

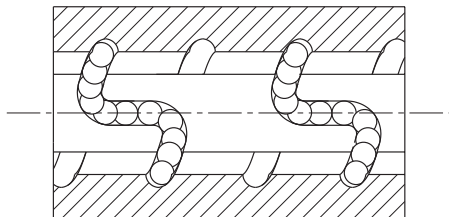

Fig 1.6.2 K - Type Nut

ABOUT BALL SCREW

1-6 Nut Design

V - Type Nut

Using outer circulation, the special design of circulator allows the balls to roll along the thread direction. By so, the smoothness of circulation is increased and meanwhile decrease the mutual collision. It's a suitable type for high speed and heavy loading.

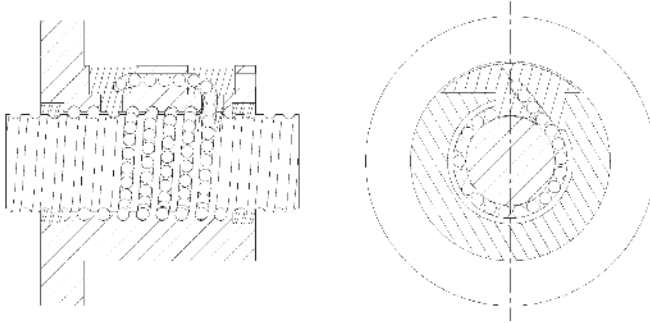

Fig 1.6.3 V - Type Nut

Y, YA, H, A, J - Type Nut

By using thin and flexible dust cap on both side, the performance of wiping had been enhanced. Moreover, the enhancement of circulation structure increase both the function of high rigidity and speed.

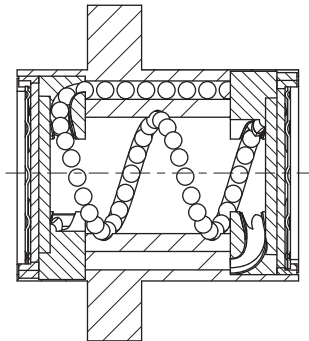

Fig 1.6.4 Y, YA, H, A, J - type nut

1-7 Rigidity

Excessively weak rigidity of the screw's peripheral structure is one of the primary causes that result in lost motion. Therefore, in order to achieve excellent position accuracy for the precision machines such as NC working machines and etc, axial rigidity balance as well as torsional rigidity for the parts at various portions of the transmission screw have to be taken into consideration at time of designing.

Static Rigidity K

The axial elastic deformation and rigidity of the transmission screw system can be determined by the formula below.

$$K = \frac{P}{e} \text{ (kgf/mm)}$$

P : Axial load (kgf) borne by the transmission screw system

e : Axial flexural displacement (mm)

$$\frac{1}{K} = \frac{1}{K_S} + \frac{1}{K_N} + \frac{1}{K_B} + \frac{1}{K_H} \text{ (mm/kgf)}$$

K_S : Axial rigidity of screw shaft (1) K_B : Axial rigidity of support shaft (3)

K_N : Axial rigidity of nut (2) K_H : Axial rigidity of installation (4)

(1) Axial rigidity K_S and displacement δ_S

$$K_S = \frac{P}{\delta_S} \text{ (kgf/mm)}$$

P : Axial load (kgf)

For places of Fixed - Fixed installation

For places other than Fixed - Fixed installation

$$\delta_{SF} = \frac{PL}{4AE} \text{ (mm)}$$

$$\delta_{SS} = \frac{PL_0}{AE} \text{ (mm)}$$

$$\delta_{SS} = 4\delta_{SF}$$

δ_{SF} : Directional displacement at places of fixed-fixed

δ_{SS} : Directional displacement at places excluding fixed-fixed installation

A : Cross-sectional area of the screw shaft tooth root diameter (mm²)

E : Longitudinal elastic modulus (2.1 · 10⁴kgf/mm²)

L : Distance between installations (mm)

L₀ : Distance between load applying points (mm)

ABOUT BALL SCREW

1-7 Rigidity

(2) Axial rigidity K_N and displacement δ_N of nuts

$$K_N = \frac{P}{\delta_s} \text{ (kgf/mm)}$$

(a) In case of single nut

$$\delta_{NS} = \frac{K}{\sin\beta} \left[\frac{Q^2}{d} \right]^{\frac{1}{3}} \cdot \frac{1}{\zeta} \text{ (mm)}$$

$$Q = \frac{P}{n \cdot \sin\beta} \text{ (kgf)}$$

$$n = \frac{D_0 \pi m}{d} \text{ (each)}$$

Q : Load of one steel ball (kgf)

n : Amount of steel ball

k : Constant determined based on material, shape, dimensions

$$k \approx 5.7 \cdot 10^{-4}$$

β : Angle of contact (45°)

P : Axial load (kgf)

d : Steel ball diameter (mm)

ζ : Accuracy, internal structure coefficient

m : Effective amount of balls

D_0 : Steel ball center diameter (mm)

$$D_0 = \frac{l}{\tan\alpha \cdot \pi} \text{ (kgf/mm)}$$

l : Lead (mm)

α : Lead angle

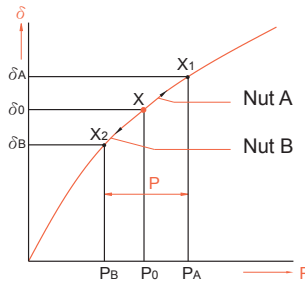

Fig 1.7.1

(b) In case of double nuts

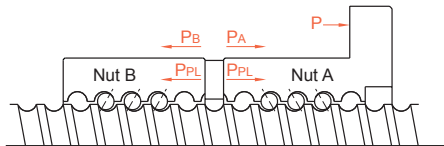

Fig 1.7.2 Preloaded for the double nuts

As bearing weight of preload (P_{PL}) exert, there will be approximately three times of axial loading (P). To eliminate the preload of nut b, please set the bearing weight of preload (P_{PL}) under 1/3 of the maximum axial load weight. Take 0.25 Ca as maximum load weight of preload. When the displacement under the preload which equals to three times of the bearing load of the axial direction, the value will be 1/2 of single nut's displacement.

$$K_N = \frac{P}{\delta_{NW}} = \frac{3P_{PL}}{\delta_{NS/2}} = \frac{6P_{PL}}{\delta_{NS}} \text{ (kgf/mm)}$$

δ_{NS} : Displacement of single nut (mm)

δ_{NW} : Displacement of double nuts (mm)

(Explanation of the rigidity of double nuts)

As shown in Fig 1.7.1 and 1.7.2, when a preload P_{PL} is applied on the nut A and B both nuts A, B would produce flexural deformations that will reach point X. If an external force P is exerted from here, nut A moves from point X to point X1, while nut B moves from X to X2.

Then, based on the computing formula for displacement δ_{NS} of the single nut, we can obtain :

$$\delta_0 = aP_{PL}^{\frac{2}{3}}$$

Since nut A and B have the displacement of $\delta_a = aP_{PL}^{\frac{2}{3}}$ while external force (P) gave the same displacement on nut A and B, we can obtain that $\delta_A - \delta_0 = \delta_0 - \delta_B$.

In other cases, if external force applied on nut A and B is P only, and cause the increase of P_A , we will get the formula of $P_A - P_B = P$ $\delta_B = 0$

$$P_A - P_B = P$$

$$\delta_B = 0$$

For preventing the external force applied on nut B being absorbed by nut A thus decreasing, so when $\delta_B = 0$

$$aP_A^{\frac{2}{3}} - aP_{PL}^{\frac{2}{3}} = aP_{PL}^{\frac{2}{3}}$$

$$P_A^{\frac{2}{3}} = 2P_{PL}^{\frac{2}{3}}$$

$$P_A = \sqrt[3]{8} P_{PL} \approx 3P_{PL}$$

As Fig 1.7.3 shown in below, if the axial direction loading weight equals to three times of preload, the single nut's displacement will be cut into half and gain two times stronger of rigidity.

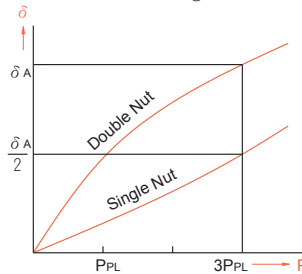

Fig 1.7.3

(3) Axial rigidity K_B and displacement δ_B of support shaft

$$K_B = \frac{P}{\delta_B} \text{ (kgf/mm)}$$

Q : Load of one steel ball (kgf)

n : Amount of steel balls

β : Angle of contact (45°)

P : Axial load (kgf)

d : Steel ball diameter (mm)

a : Effective stroke

$$\delta_B = \frac{2}{\sin\beta} \left[\frac{Q^2}{d} \right]^{\frac{1}{3}} \text{ (mm)} \quad Q = \frac{P}{n \cdot \sin\beta} \text{ (kgf)}$$

(4) Look into the nut and bearing mounting part's axial direction, the rigidity K_H and displacement δ_H should aware of the requirement of high rigidity on mounting portion during the initial machine development.

$$K_H = \frac{P}{\delta_H} \text{ (kgf/mm)}$$

ABOUT BALL SCREW

1-8 Positioning Accuracy

Among the factors that cause feed accuracy errors, lead accuracy and feed system rigidity are the key points for review, while other factors such as heat deformation due to temperature rise as well as assembly accuracy for the guiding surface, etc. should also be considered.

■ 1-8-1 Accuracy Selection

Table 1.8.1 shows the recommended application ranges for various ball screws accuracy classes based on different.

Table 1.8.1 Examples of ball screws accuracy classes for different uses

Application			Accuracy Grade						
			C0	C1	C2	C3	C5	C7	C10
NC Machine Tools	Lathe	X	○	○	○	○	○	○	
		Y				○	○	○	
	Milling Machine Boring Machine	XY		○	○	○	○	○	
		Z			○	○	○	○	
	Machine Center	XY		○	○	○	○		
		Z			○	○	○		
	Jig Borer	Y	○	○					
		Z	○	○					
	Drilling Machine	XY				○	○	○	
		Z					○	○	
	Grinding Machine	X	○	○	○	○	○	○	
		Z		○	○	○	○	○	
	Electro-discharge Machine (EDM)	XY		○	○	○	○	○	
		(Z)			○	○	○	○	
	Wire Cut (EDM)	Y		○	○	○			
UV			○	○	○	○	○		
Punching Press	XY				○	○	○		
Laser Cutting Machine	XY				○	○			
	Z				○	○			
Wood Working Machine					○	○	○	○	
Machines of General use and special Use					○	○	○	○	
Semiconductor Machines	Explosure Equipments		○	○					
	Chemical Treatment					○	○	○	○
	Wire Bonder			○	○	○			
	Prober		○	○	○	○			
	Inserter				○	○	○	○	
PCB Driller			○	○	○	○	○		
Industrial Robots	Orthogonal Type	As'sy		○	○	○	○	○	
		Others					○	○	○
	Multi-joints Type	As'sy			○	○	○		
		Others				○	○	○	
SCARA Type				○	○	○	○		
Machines for Steel molding						○	○	○	
Injection Molding Machines						○	○	○	
Three-Dimensional Measuring Machines			○	○	○				
Business Machines						○	○	○	
Pattern Image Machines			○	○					
Nuclear	Rod Control					○	○	○	
	Mechanical Snubber						○	○	
Aircrafts						○	○		

■ 1-8-2 Countermeasure Against Thermal Displacement

Thermal displacement of the screw shaft results in deterioration of the position accuracy. The magnitude of the thermal displacement is calculated as follows :

$$\Delta \ell = \alpha \cdot \Delta t \cdot L$$

$\Delta \ell$: Thermal displacement

α : Coefficient of thermal expansion

Δt : Temperature rise (deg) at screw shaft

L : Effective length of screw thread

Namely, the screw shaft develops elongation of 12 μ m per 1m when the temperature rises by 1°C. The ball screw, which lead has been machined to high accuracy, may fail to meet high level requirements because of the thermal displacement due to temperature rise. As high speed is applied during ball screw usage, the heat will rise as well and cause more influence.

The thermal displacement countermeasures for ball screws include the following :

(1) Control of heat generation

- Optimization of preload
- Correct selection and supply of lubricant
- Increase in ball screw lead, with reduced rotation speed

(2) Forced cooling

- Hollow screw shaft to allow cooling fluid to flow through
- Cooling of screw shaft exterior with cooling oil or air

(3) Avoid influence of temperature rise

Warming up the machine through high speed to attain the stable temperature :

- Operates after the temperature become stable
- Pre-tension on screw shaft
- Preset a negative value on target value of the cumulative lead.
- Use the closed loop for positioning

ABOUT BALL SCREW

1-9 Service Life Design

■ 1-9-1 Service Life of Ball Screws

Even the ball screw is used under correct conditions, it would still fail after a period time of usage. From the beginning to the unusable condition of ball screw, this period of time is called service life of ball screw, which is generally classified into the fatigue life when delamination phenomenon occurs and the accuracy deterioration life caused by wear-out, etc.

■ 1-9-2 Basic Static Load Rating C_{0a}

The basic load rating is an axial load which will produce a permanent deformation at contact points of the steel balls to ball grooves equal to 0.01% of ball diameter.

■ 1-9-3 Basic Dynamic Load Rating C_a

The basic dynamic load rating is an axial load which allow 90% of a group of identical ball screws (rotated under the same condition) to rotate without flaking for 10^6 revolutions. This basic dynamic load rating is shown in the table of dimensions.

Relation between load and service life $L_a = \left(\frac{1}{P}\right)^3$ L : Service life P : Load

■ 1-9-4 Fatigue Life

Average load P_e

(1) When axial load keeps changing, please calculate in order the average load for the equivalent fatigue life under different load condition changes. (see Table 1.9.1)

$$(P_e = \frac{P_1^3 n_1 t_1 + P_2^3 n_2 t_2 + \dots + P_n^3 n_n t_n}{n_1 t_1 + n_2 t_2 + \dots + n_n t_n})^{\frac{1}{3}} \text{ (kgf)})$$

Axial Load (kgf)	Rotating Speed (min ⁻¹)	Time(%)
P1	n1	t1
P2	n2	t2
⋮	⋮	⋮
⋮	⋮	⋮
Pn	nn	tn

But, $t_1 + t_2 + t_3 + \dots + t_n = 100$

Table 1.9.1 Service Life in Different Application.

Usage	Life in hours (h)
Working machines	20000
General industrial machines	10000
Automatic control machines	15000
Measurement machines	15000

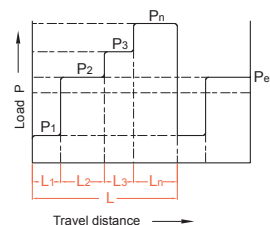

Fig 1.9.1

$$P_e = \frac{2P_{max} + P_{min}}{3} \text{ (kgf)}$$

P_{max} : Maximal axial load (kgf)

P_{min} : Minimal axial load (kgf)

(2) When load changes according to sine curve (see Fig 1.9.2)

$P_e \cong 0.65 P_{max}$ (Fig A)

$P_e \cong 0.75 P_{max}$ (Fig B)

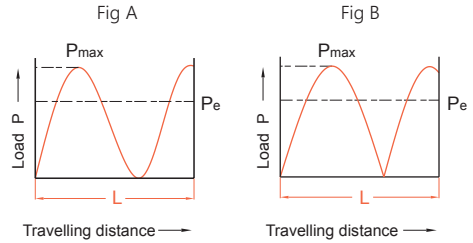

Fig 1.9.2

■ 1-9-5 Calculation of Service Life

The fatigue life is generally expressed by the total number of revolutions. The total rotation hours or total travel distance may also be used to express service life. The fatigue life is calculated as follow :

$$L = \left[\frac{C_a}{P_a \cdot f_w} \right]^3 \cdot 10^6$$

$$L_t = \frac{L}{60n}$$

$$L_s = \frac{L \cdot \ell}{10^6}$$

Where

L : Rated fatigue life (rev)

L_s : Life in travel distance (km)

P_a : Axial load (kgf)

f_w : Load Coefficient

(Required coefficient to operate)

L_t : Life in hours (h)

C_a : Basic dynamic load rating (kgf)

n : Rotating speed (rpm)

ℓ : Lead (mm)

Table 1.9.2 Load Factor (f_w)

Vibration and impact	Velocity (V)	f_w
Minor	$V \leq 0.25$ m/s Very Low	1~1.2
Little	$0.25 < V \leq 1$ m/s Low	1.2~1.5
Moderate	$1 < V \leq 2$ m/s Medium	1.5~2
Heavy	$V > 2$ m/s High	2~3.5

Table 1.9.3 Factor of Safety (f_s)

Usage	Operation	f_s
Machine tool	Normal operation	1.0 ~ 1.3
	Operation with impact and vibration	2.0 ~ 3.0
Industrial machine	Normal operation	1.0 ~ 1.5
	Operation with impact and vibration	2.5 ~ 7.0

Basic Dynamic Load Rating C_a

$$C_a = P_e \cdot f_s$$

Basic Static Load Rating C_{0a}

$$C_{0a} = P_{max} \cdot f_s$$

ABOUT BALL SCREW

1-9 Life Design

Key Points for Ball Screws Selection

To choose a perfect fit ball screw, users need to understand operating requirement, which is the fundamental principal of deciding the design. Besides, the main factors of selection include load weight, stroke, torque, positioning accuracy in a single time and repeatedly, rigidity, lead and nut's inner diameter. Among all the factors, any single factor's change will cause the change of other factors. Therefore, the balance between all factors is a must to pay attention to.

Calculation for Ball Screws Selection

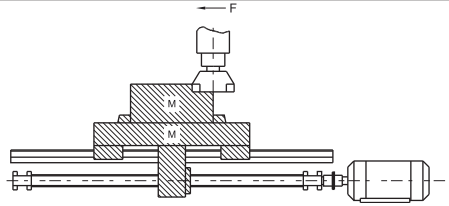

Design conditions

1. Working table weight 300 Kg
2. Working object weight 400 Kg
3. Max Stroke 700 mm
4. Feeding speed 10 m/min
5. Minimal disassembly ability 10μm/stroke
6. Driving motor DC motor (MAX 1000 min)
7. Guiding surface friction coefficient (μ= 0.05~0.1)
8. Running rate 60 %
9. Accuracy review items
10. Inertia generated during acceleration/deceleration can be neglected because the time periods involved are comparatively small.

1. Setting of operation conditions

(a) Machine service life time calculation of H (hr)

$$H = \left[\text{hours/day} \right] \cdot \left[\text{days/year} \right] \cdot \left[\text{life years} \right] \cdot \left[\text{running rate} \right]$$

(b) Mechanical conditions

Calculation Items / Different Operations	Speed/rotations	Cutting resistance	Sliding resistance	Time used
Fast feed	m/min/min ⁻¹	kgf	kgf	%
Light cutting	/			
Medium cutting	/			
Heavy cutting	/			

(c) Position determination accuracy

Feed accuracy error factor includes load accuracy and system rigidity. Other factors which caused by temperature rise such as heat deformation and mounting accuracy of surface are needed to be considered.

1. Setting of operation conditions

(a) Machine service life time calculation of H (hr)

$$H = 12 \text{ hr} \cdot 250 \text{ days} \cdot 10 \text{ years} \cdot 0.6 \text{ Running rate} = 18000 \text{ hr}$$

(b) Mechanical conditions

Calculation Items / Different Operations	Speed/rotations	Cutting resistance	Sliding resistance	Time used
Fast feed	10 _m /min/1000 _{min} ⁻¹	0 kgf	70 kgf	10 %
Light cutting	6/600	100	70	50
Medium cutting	2/200	200	70	30
Heavy cutting	1/100	300	70	10

$$\text{Sliding resistance} = (300 + 400) \cdot 0.1 = 70 \text{ kgf}$$

Key Points for Ball Screws Selection	Calculation for Ball Screws Selection
<p>2. Ball screw lead l (mm)</p> $l = \frac{\text{Feeding speed (m/min)} \cdot 1000}{\text{Max. Rotating speed (min}^{-1}\text{) of motor}} \text{ (mm)}$	<p>2. Ball screw lead l (mm)</p> $l = \frac{10000}{1000} = 10 \text{ (mm)}$ <p>Minimal disassembly = $\frac{10 \text{ mm}}{1000 \text{ stroke}}$ = 0.01 mm/stroke</p>
<p>3. Computation of average load P_e (kgf)</p> $P_e = \left[\frac{P_1^3 n_1 t_1 + P_2^3 n_2 t_2 + \dots + P_n^3 n_n t_n}{n_1 t_1 + n_2 t_2 + \dots + n_n t_n} \right]^{\frac{1}{3}}$ $P_e = \frac{2P_{\max} + P_{\min}}{3}$ <p>$P_e \approx 0.65 P_{\max}$ $P_e \approx 0.75 P_{\max}$</p>	<p>3. Computation of average load P_e (kgf)</p> $P_e = \left[\frac{70^3 \cdot 1000 \cdot 10 + 170^3 \cdot 600 \cdot 50 + 270^3 \cdot 200 \cdot 30 + 370^3 \cdot 100 \cdot 10}{1000 \cdot 10 + 600 \cdot 50 + 200 \cdot 30 + 100 \cdot 10} \right]^{\frac{1}{3}}$ $= \left[\frac{31.7 \cdot 10^{10}}{4.7 \cdot 10^4} \right]^{\frac{1}{3}}$ <p>$\approx 189 \text{ kgf}$</p>
<p>4. Average number of rotations n_m</p> $n_m = \frac{n_1 t_1 + n_2 t_2 + \dots + n_n t_n}{100}$	<p>4. Average number of rotations n_m</p> $n_m = \frac{1000 \cdot 10 + 600 \cdot 50 + 200 \cdot 30 + 100 \cdot 10}{100}$ $= \frac{4.7 \cdot 10^4}{100} = 470 \text{ min}^{-1}$
<p>5. Calculation of required dynamic rated load C_a</p> $C_a = P_e \cdot f_s$	<p>5. Calculation of required dynamic rated load C_a</p> $C_a = 189 \cdot 5 = 945 \text{ (kgf)}$
<p>6. Calculation of required static rated load C_{0a}</p> $C_{0a} = P_{\max} \cdot f_s$	<p>6. Calculation of required static rated load C_{0a}</p> $C_{0a} = 369 \cdot 5 = 1845 \text{ (kgf)}$
<p>7. Selection of nut type</p> <p>$C_a > 945$ $C_{0a} > 1845$ Select the nut types with basic dynamic rated load and basic static rated load as specified above.</p>	<p>7. Selection of nut type</p> <p>Choose SFNI 2510 on the catalogue $C_a = 2954 \text{ (kgf)}$ $C_{0a} = 7295 \text{ (kgf)}$</p>

ABOUT BALL SCREW

1-9 Life Design

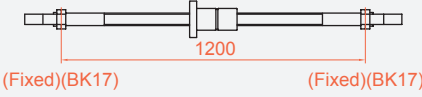
Key Points for Ball Screws Selection	Calculation for Ball Screws Selection
<p>8. Calculation of service life L_t (h)</p> $L_t = \frac{L}{60n} = \left(\frac{C_a}{P_e \cdot f_w} \right)^3 \cdot 10^6 \cdot \frac{1}{60n}$	<p>8. Calculation of service life L_t (h)</p> $L_t = \left(\frac{2954}{189 \cdot 2} \right)^3 \cdot 10^6 \cdot \frac{1}{60 \cdot 470} = 42544(\text{h})$
<p>9. Mounting distance between supporting bearings</p>	<p>9. Mounting distance between supporting bearings</p> 
<p>10. Determination of screw length</p> <p>Screw length = Maximal stroke + Nut length + Two reserved length at shaft end</p>	<p>10. Determination of screw length</p> <p>Screw length = 700 + 85 + 76 + 76 = 937 mm 937 mm < 1200 mm</p>
<p>11. Permissible axial load</p>	<p>11. Permissible axial load</p> <p>Omitted because of F-F support</p>
<p>12. Permissible revolution speed n and DN</p> $n = \alpha \cdot \frac{60\lambda^2}{2\pi L^2} \sqrt{\frac{E\lambda g}{\gamma A}} = f \frac{dr}{L^2} \cdot 10^7 (\text{rpm})$ <p>DN = Shaft dia · Maximal speed</p>	<p>12. Permissible revolution speed n and DN</p> $n = \frac{21.9 \cdot 21.86 \cdot 10^7}{1200^2} = 3324 \text{ min}^{-1} < n_{\text{max}}$ <p>DN = 25 · 1000 = 25000 < 50000</p>
<p>13. Countermeasure against thermal displacement</p> $\Delta l = \alpha \cdot \Delta t \cdot L$ <p>Δl: Thermal displacement α: Coefficient of thermal expansion Δt: Temperature rise (deg) at screw shaft L: Effective length of screw thread</p>	<p>13. Countermeasure against thermal displacement</p> <p>It is estimated there would be a temperature rise 2~5°C with the ball screws of the general machinery, take temperature rise of 2°C to compute the extension of ball screw.</p> $\Delta l = \alpha \cdot \Delta t \cdot L = 11.7 \cdot 10 \cdot 2 \cdot 700 \text{ mm}$ $\approx 0.016 \text{ mm}$ $F_p = \frac{EA \Delta l}{L}$ $= \frac{2.06 \cdot 10^4 \cdot \pi \cdot 21.86^2 \cdot 0.016}{700}$ $\approx 177 (\text{kgf})$

Key Points for Ball Screws Selection	Calculation for Ball Screws Selection
<p>14. Rigidity</p> <p>(1) Axial rigidity K_s and displacement δ_s of screw shaft</p> $K_s = \frac{P}{\delta_s} \text{ (kgf/mm)}$ <p>P : Axial load (kgf)</p> $\delta_{SF} = \frac{PL}{4AE} \text{ (mm)} \dots\dots \text{(with reference to page C21)}$ <p>(2) Axial rigidity K_N and displacement δ_s of nut</p> $\delta_{NS} = \frac{K}{\sin\beta} \left[\frac{Q^2}{d} \right]^{\frac{1}{3}} \cdot \frac{1}{\xi} \text{ (mm)}$ $Q = \frac{P}{n \cdot \sin\beta} \text{ (kgf)}$ $n = \frac{D_0 \pi m}{d} \text{ (each)} \dots\dots \text{(with reference to page C22)}$ <p>(3) Axial rigidity K_B and displacement δ_B of bracing shaft</p> $K_B = \frac{P}{\delta_B} \text{ (kgf/mm)} \dots\dots \text{(with reference to page C23)}$	<p>14. Rigidity</p> <p>Deviation can be corrected by estimating the temperature rise per extension of 0.016 mm, and taking into consideration of the pre-tension of 177 kgf.</p> <p>(1) Directional rigidity</p> $\delta_{SF} = \frac{PL}{4AE} = \frac{27 \cdot 1200}{4 \cdot \pi \cdot 21.86^2 \cdot 2.06 \cdot 10^4}$ $= 0.00105 \text{ (mm)}$ $K_s = \frac{370}{0.00105} = 3.5 \cdot 10^5 \text{ kgf/mm}$ <p>(2) Rigidity of steel ball and nut groove</p> $n = \frac{26.62 \cdot \pi \cdot 4}{4.762} = 70$ $Q = \frac{370}{70 \sin 45^\circ} = 10$ $\delta_{NS} = \frac{0.00057}{\sin 45^\circ} \left(\frac{10^2}{4.762} \right)^{\frac{1}{3}} \cdot \frac{1}{0.7}$ $= 3.2 \cdot 10 \text{ mm}$ $K_N = \frac{370}{3.2 \cdot 10^{-3}} = 1.27 \cdot 10^5 \text{ kgf/mm}$ <p>(3) Rigidity of support bearings</p> <p>Where, nut rigidity 50 kgf/μm</p> $\delta_B = \frac{370}{51 \cdot 2} = 3.6 \mu\text{m}$ $K_B = \frac{370}{0.0036} = 1 \cdot 10^5 \text{ kgf/mm}$ <ul style="list-style-type: none"> • $\delta_{TOTAL} = 1.05 + 3.2 + 3.6 = 7.85 \mu\text{m}$
<p>15. Confirmation of the ball screw life</p>	<p>15. Confirmation of the ball screw life</p> $L = 42544 \text{ (h)} > 18000 \text{ (h)}$

ABOUT BALL SCREW

1-10 Cautions About Use of Ball Screws

Ball screw assemblies are delicate components. Therefore, extra care must be taken to prevent the ball track from damages that caused by edged component or tools. Meanwhile, to prevent steel ball fall out of the nut through the disassembly of screw and nut or over stroke, please be careful while operating. If the steel ball falls out, please contact with TBI MOTION for further instruction. (Do not attempt to reassemble, which might cause permanent damage to the ball screw.)

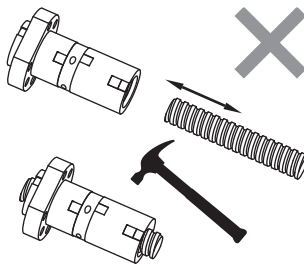

Fig 1.10.1 Error installation

If disassemble is required, please use a transfer pipe which has minor diameter than the screw diameter to transfer the nut to prevent falling out of the steel balls.

■ 1-10-1 Lubrication

Adequate lubrication must be provided when ball screw is used, insufficient lubrication will result in collision of metal, which leads to increase of friction and detrition, thus cause failure or shortening the service life.

Lubricants applied to ball screws can be divided into 2 types, namely lubricating oil and consistent grease. In general speaking, in respect of maintenance, consistent grease will lead to increase of dynamic friction torque linearly along with increase of rotating speed, hence oil lubrication is deemed the better way when speed exceeds 3-5 m/min; however, don't forget the fact that there have been examples that using grease has been capable of achieving speed of 10 m/min, with respect to the equipment.

In terms of equipments, there are some cheaper lubricant that can be used. In general, to fully utilize the function of ball screw, lubricating oil of 5m/minute is the best option to choose. In figure 1.10.1, we provide the standard of lubricating oil inspection and supplement interval. Before replenishing, please clean up the previous grease to continue.

Table 1.10.1 Inspection of lubrication and interval of refill

Method	Interval	Check Item	Replenish or Change Interval
Auto. Periodical oil supply	Weekly	Oil level, contamination	Add at each check, as required depending on tank level
Grease	Initially 2~3 months	Contamination on entry of chip	replenish yearly or according to the inspection result.
Oil bath	Daily	Oil level	To be determined according to consumption

■ 1-10-2 Dust Proof / Prevention

Any foreign matter or water, if entering to the ball screw, may increase friction and cause damage. For example, the entry of chips or cutting oil may be expected with machine tools according to the work environment. Where entry of foreign matter is anticipated, use a bellows or telescopic cover as shown in Fig 1.10.2, to cover the screw shaft completely.

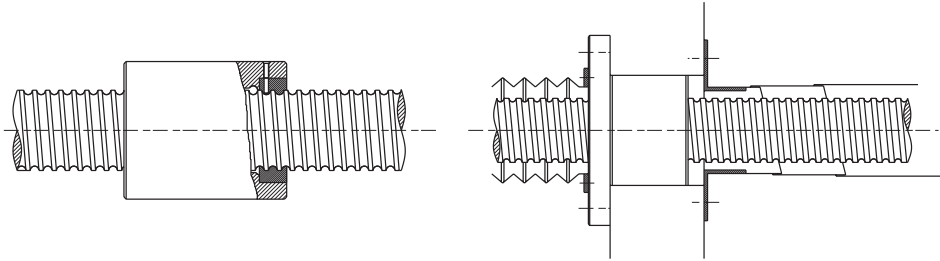

Fig 1.10.2 Dust proof Method by Telescopic Cover and Bellows

■ 1-10-3 Offset Load

When offset load phenomenon occurs, screw life and noise tend to be directly affected, which would usually be accompanied with hand feel of rough running. As the smoothness of single shaft and assembled ball screw might be different. In addition to single shaft's accuracy, the offset phenomenon was mostly occurred by failed assemble accuracy which is shown in Fig 1.10.3.

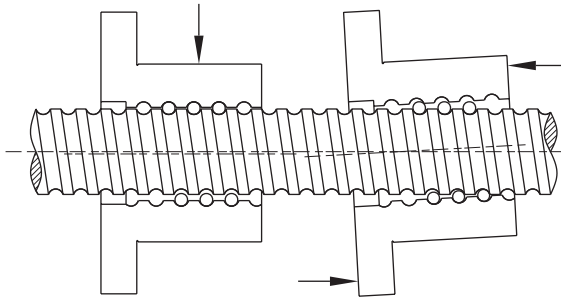

Fig 1.10.3 Offset Load

ABOUT BALL SCREW

1-10 Cautions About Use of Ball Screws

■ 1-10-4 Assembling the Ball Screws

If rolled ball nut is shipped un-assembled please follow the procedure as below.

Table 1.10.2 Procedure

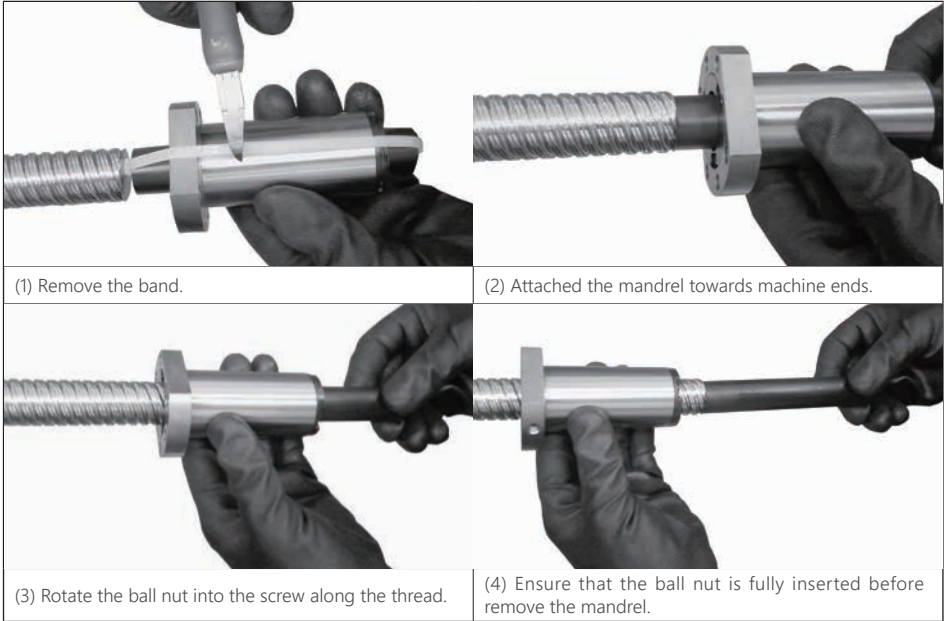

■ 1-10-5 Machining Specifications

(1) For the Ball Screws with internal or end cap type circulation ball nut, it is required to have at least one end with complete thread to the end of screw, it is also required to have the journal area is with diameter to be smaller than the diameter of thread root as Fig 1.10.4 shown.

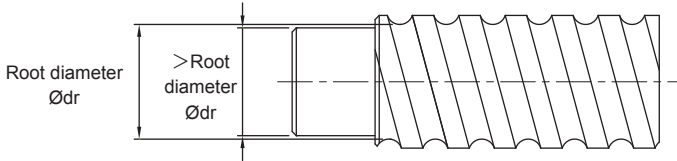

Fig 1.10.4 For Internal Circulation

(2) The thread on screw shaft are hardened by induction hardening. It shall cause about 10~20mm at both ends journal purpose. The unhardened area will be labeled.

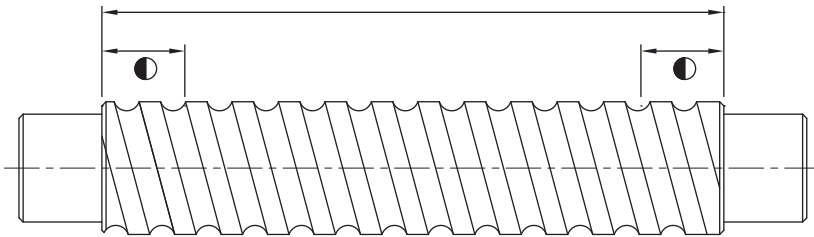

Fig 1.10.5 Harden Area

TBI MOTION BALL SCREW

2-1 Nominal Model Code of Ball Screw

SFU R 025 05 T4 D G C5 - 600 - P1 - B2 + N3 N3

①
②
③
④
⑤
⑥
⑦
⑧
⑨
⑩
⑪
⑫
⑬

①	②	⑤	⑦
Nominal Model	Threading Direction	Number of Turns (Turn-Row)	Product Code
S : Single nut	R : Right	Turn : T : 1	G : Ground
F : With flange	L : Left	A : 1.5 (or 1.7/1.8)	F : Rolled
C : Without flange		B : 2.5/2.8	
NI : NI type nut	③	C : 3.5	⑧
NU : NU type nut	Nominal Diameter	D : 4.8	Accuracy Grade
H : H type nut	Unit : mm	E : 5.8	C0, C1, C2, C3, C5, C7, C10
A : A type nut		ex : (2.5 × 2 = B2)	
J : J type nut			
NH : NH nut (A solution for slide table)	④	⑥	⑨
U	Lead	Flange Type	Overall Length of Shaft
Y : Y type nut	Unit : mm	N : Not cutting	Unit : mm
YA : YA type nut		S : Single cutting	
V : V type nut		D : Double cutting	
U : U type nut			
M : M type nut			
K : K type nut			

⑩	⑪
Axial Clearance and Preload Value	Number of Nut
P0, P1, P2, P3, P4	(Leave blank if only one nut is required) Ex : Install two nuts on a shaft B2

⑫	⑬
Nut Surface Treatment	Shaft Surface Treatment
S : Standard	S : Standard
B1 : Black Oxidation	B1 : Black Oxidation
N1 : Hard Chrome Plating	N1 : Hard Chrome Plating
P : Phosphating	P : Phosphating
N3 : Nickel Plating	N3 : Nickel Plating
N4 : Raydent	N4 : Raydent
N5 : Chrome Plating	N5 : Chrome Plating

※ No symbol required when plating is not needed.

※ An inspection report is provided for ground ball screws with an accuracy higher than C5.

C

Ball Screw

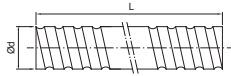

Fig 2.1.1 Screw Shaft Nominal Diameter

Table 2.1.1 Ground Ball Screw Specifications Ø4~32

Model No.			Accuracy Grade	Threading Direction	Number of Grooves	Standard Code of Shaft	Type of Nut
Ød	l	Da		R : Right L : Left			
4	1	0.8	C7, C5, C3	R	1	SCR00401	K
	6	1.2	C7, C5, C3	R	1	SCR00601	K
6	1	0.8	C7, C5, C3	R	1	SCR00606	J
	2	1.2	C7, C5, C3	R/L	1	SCR00801	K
	2.5	1.2	C7, C5, C3	R	1	SCR00802	K
	8	1.2	C7, C5, C3	R	1	SCR0082.5	K, BSH
	2	1.2	C7, C5, C3	R/L	1	SCR00808	J
	4	2	C7, C5, C3	R	1	SCR01002	K, BSH
8	2	1.2	C7, C5, C3	R/L	1	SCR01004	K, BSH
	4	2.5	C7, C5, C3	R	1	SCR01202	K
	5	2.5	C7, C5, C3	R	1	SCR01204	U, BSH
	10	2.5	C7, C5, C3	R	1	SCR01205	K
10	2	1.2	C7, C5, C3	R	1	SSR01205	V, BSH, H, A, J
	4	2.5	C7, C5, C3	R	1	SCR01210-B	V
	2	1.2	C7, C5, C3	R/L	1	SCR01402	K
	4	2.5	C7, C5, C3	R	1	SCR01404	K, BSH
14	10	3.175	C7, C5, C3	R	1	SCR01510	V
	20	3.175	C7, C5, C3	R	1	SCR01520	V
15	2	1.2	C7, C5, C3	R/L	1	SCR01602	K
	4	2.381	C7, C5, C3	R	1	SCR01604(N)	V, I, U, BSH
	5	3.175	C7, C5, C3	R/L	1	SCR01605	V, NI, NU, BSH
	10	3.175	C7, C5, C3	R/L	1	SCR01610	V, NI, NU, BSH
	16	2.778	C7, C5, C3	R	2	SCR01616	Y, YA
	32	2.778	C7, C5, C3	R	2	SCR01632	Y, YA
16	2	1.2	C7, C5, C3	R	1	SCR02002	K
	4	2.381	C7, C5, C3	R	1	SCR02004(N)	V, I, U
	5	3.175	C7, C5, C3	R/L	1	SCR02005	V, NI, NU, BSH, H, A, J
	10	3.969	C7, C5, C3	R	1	SCR02010	V
	20	3.175	C7, C5, C3	R	1	SCR02020	H, A, J
	20	3.175	C7, C5, C3	R	2	SCR02020	V, Y, YA
	40	3.175	C7, C5, C3	R	2	SCR02040	Y, YA
20	2	1.2	C7, C5, C3	R	1	SCR02502	K
	4	2.381	C7, C5, C3	R	1	SCR02504(N)	I, U
	5	3.175	C7, C5, C3	R/L	1	SCR02505	V, NI, NU, BSH, H, A, J
	6	3.969	C7, C5, C3	R	1	SCR02506	V, U
	8	4.762	C7, C5, C3	R	1	SCR02508	V, U
	10	4.762	C7, C5, C3	R/L	1	SCR02510-A	NI, NU, BSH
	10	6.35	C7, C5, C3	R	1	SCR02510-B	V
	25	3.969	C7, C5, C3	R	2	SCR02525	Y, YA
	50	3.969	C7, C5, C3	R	2	SCR02550	Y, YA
25	4	2.381	C7, C5, C3	R	1	SCR03204(N)	V, I, U
	5	3.175	C7, C5, C3	R/L	1	SCR03205	V, NI, NU, M, H, A
	6	3.969	C7, C5, C3	R	1	SCR03206	V, U
	8	4.762	C7, C5, C3	R	1	SCR03208	V, U
	10	6.35	C7, C5, C3	R/L	1	SCR03210	V, NI, NU
	20	6.35	C7, C5, C3	R	1	SCR03220	V
	32	4.762	C7, C5, C3	R	2	SCR03232	Y, YA
	64	4.762	C7, C5, C3	R	2	SCR03264	Y, YA

TBI MOTION BALL SCREW

2-1 Nominal Model Code of Ball Screw

Table 2.1.2 Standard Specifications Ø40~80

Unit : mm

Ød	Model No.		Accuracy Grade	Threading Direction R : Right L : Left	Number of Grooves	Standard Code of Shaft	Type of Nut
	I	Da					
40	5	3.175	C7, C5, C3	R / L	1	SCR04005	V, NI, NU, H, A
	6	3.969	C7, C5, C3	R	1	SCR04006	V, U
	8	4.762	C7, C5, C3	R	1	SCR04008	V, U
	10	6.35	C7, C5, C3	R / L	1	SCR04010	V, NI, NU
	20	6.35	C7, C5, C3	R	1	SCR04020	V
	40	6.35	C7, C5, C3	R	2	SCR04040	Y, YA
	60	6.35	C7, C5, C3	R	2	SCR04080	Y, YA
50	5	3.175	C7, C5, C3	R	1	SCR05005	V, H, A
	10	6.35	C7, C5, C3	R / L	1	SCR05010	V, NI, NU
	20	7.144	C7, C5, C3	R	1	SCR05020	NU
	20	9.525	C7, C5, C3	R	1	SCR05020	V
	50	7.938	C7, C5, C3	R	2	SCR05050	Y, YA
	100	7.938	C7, C5, C3	R	2	SCR050100	Y, YA
63	10	6.35	C7, C5, C3	R	1	SCR06310	V, NI, NU
	20	9.525	C7, C5, C3	R	1	SCR06320	V, NU
80	10	6.35	C7, C5, C3	R	1	SCR08010	V, NI, NU
	20	9.525	C7, C5, C3	R	1	SCR08020	V, NU

Table 2.1.3 H/A/J-type Specifications Ø16~50

Unit : mm

Ød	Model No.		Accuracy Grade	Threading Direction R : Right L : Left	Number of Grooves	Type-H Code of Shaft	Type of Nut
	I	Da					
12	10	2.5	C7, C5, C3	R	1	SSR01210	H, A, J
16	5	2.778	C7, C5, C3	R	1	SSR01605	H, A, J
	10	2.778	C7, C5, C3	R	1	SSR01610	H, A, J
	16	2.778	C7, C5, C3	R	1	SSR01616	H, A, J
	20	2.778	C7, C5, C3	R	1	SSR01620	H, A, J
	30	2.778	C7, C5, C3	R	1	SSR01630	A
20	10	3.175	C7, C5, C3	R	1	SSR02010	H, A, J
25	10	3.175	C7, C5, C3	R	1	SSR02510	H, A, J
	25	3.175	C7, C5, C3	R	1	SSR02525	H, A, V, J
32	10	3.969	C7, C5, C3	R	1	SSR03210	H, A
	20	3.969	C7, C5, C3	R	1	SSR03220	H, A
	32	6.35	C7, C5, C3	R	1	SSR03232	H, A
40	10	6.35	C7, C5, C3	R	1	SSR04010	H, A
	20	6.35	C7, C5, C3	R	1	SSR04020	H, A
	40	6.35	C7, C5, C3	R	1	SSR04040	H, A
50	10	6.35	C7, C5, C3	R	1	SSR05010	H, A
	20	6.35	C7, C5, C3	R	1	SSR05020	H, A
	50	6.35	C7, C5, C3	R	1	SSR05050	H, A

※The information is for specifications, if customized products are needed please contact **TBI MOTION**.

2-2 Precision Ground Ball Screw Series

2-2-1 TBI MOTION Nut of Precision Ground Ball Screw Type

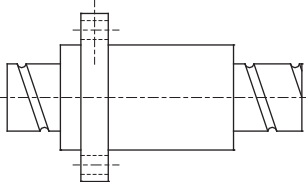
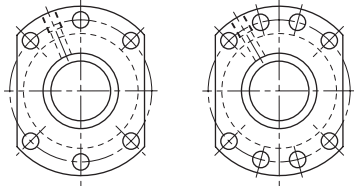
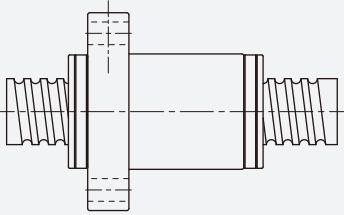
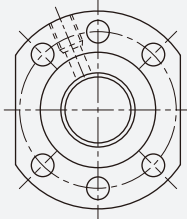
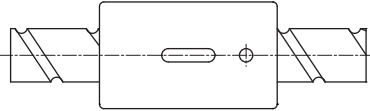
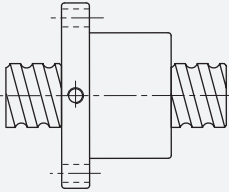
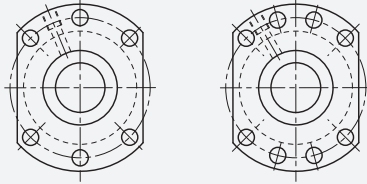
	Nut Type	Flange Type
NH/H/A (A solution for slide table/High Speed/Strong dust-proof type)	<p>SFNH/SFH/SFA (DIN)</p>  <p>C44-45</p>	 <p>$d \leq 32$ $d \geq 40$</p>
J (Low Noise/Strong dust-proof type)	<p>SFJ (DIN)</p>  <p>C46</p>	
CNH (A solution for slide table)	<p>SCNH</p>  <p>C47</p>	No-Flange
NU/U (Strong dust-proof type)	<p>SFNU/SFU (DIN)</p>  <p>C48</p>	 <p>$d \leq 32$ $d \geq 40$</p>

TBI MOTION BALL SCREW

2-2 Precision Ground Ball Screw Series

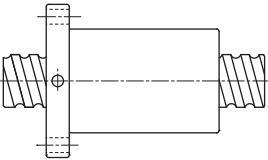
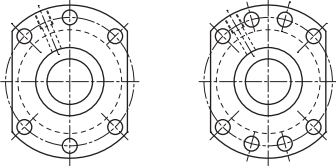
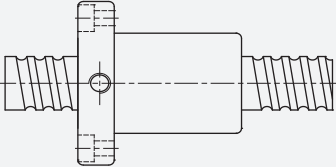
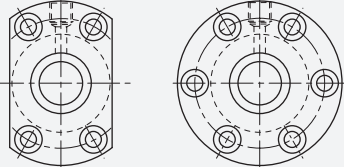
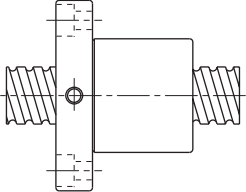
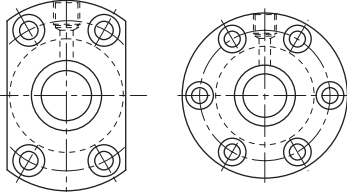
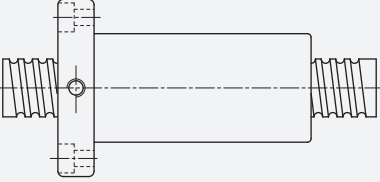
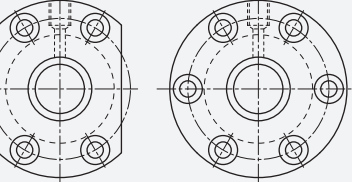
	Nut Type	Flange Type
OFU (OFF set double nut)	<p>OFU (DIN)</p>  <p>C49</p>	
NI/ (Strong dust-proof type)	<p>SFNI/SFI</p>  <p>C50</p>	
M (Design for Milling)	<p>SFM</p>  <p>C50</p>	
OFI (OFF set double nut)	<p>OFI</p>  <p>C51</p>	



Ball Screw

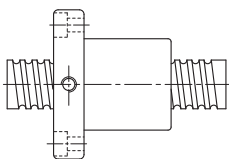
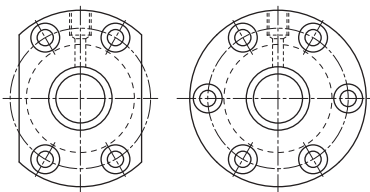
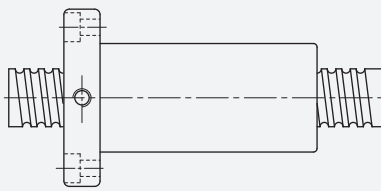
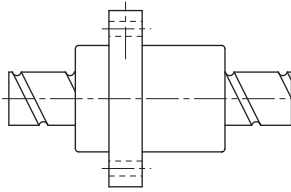
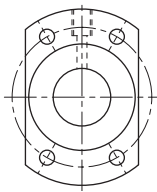

Nut Type		Flange Type
∨ (High Load External Circulation type)	<p>SFV</p>  <p>C52</p>	
OFV (OFF set double nut)	<p>OFV</p>  <p>C53</p>	
Y/YA (High DM-N Rating)	<p>SFY/SFYA</p>  <p>C54, 55</p>	

TBI MOTION BALL SCREW

2-2 Precision Ground Ball Screw Series

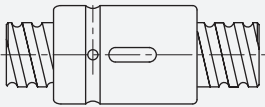
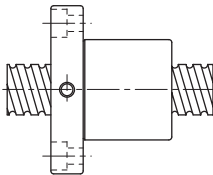
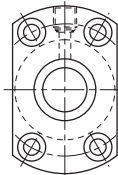
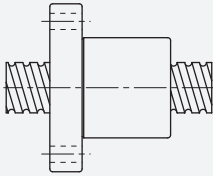
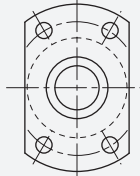
		Nut Type	Flange Type
CNI/I (Standard)		<p>SCNI/SCI</p>  <p>C56</p>	No-Flange
	K (Miniature type)	<p>SFK</p>  <p>C57</p>	 <p>(SFK 01004) (SFK 02002) (SFK 02502)</p>
		<p>SFK</p>  <p>C57</p>	

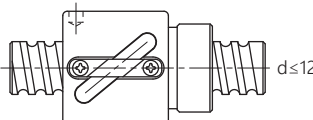
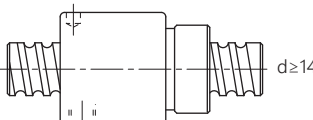
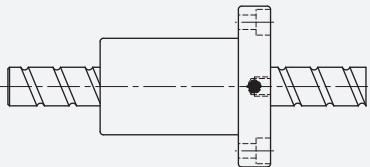
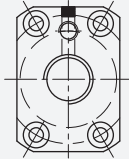
Nut Type		Flange Type
BSH	<p>BSH</p>  <p>$d \leq 12$</p>  <p>$d \geq 14$</p>	No-Flange
	C58	
XSV (Design for factory automation)	<p>XSV</p>  <p>C59~63</p>	

※ The information is for specifications, if customized products is are needed please contact **TBI MOTION**.

Table 2.2.1 Preload Chart

Preload	I, U, M-type	H, A, J-type	Y, YA-type	V-type	BSH-type	K-type
P0						
P1	√	√	√	√	√	√
P2	√	√	√	√	√	
P3	√	√	√	√	√	
P4				√		

TBI MOTION BALL SCREW

2-2 Precision Ground Ball Screw Series

SFNH/SFH (DIN 69051 FORM B) Series Specifications

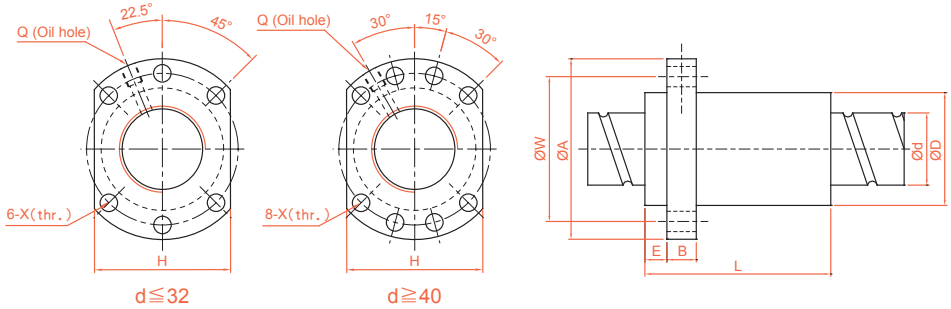

Unit : mm

Model No.	d	l	Da	Dimension										Load Rating		K kgf/μm
				D	A	E	B	L	W	H	X	Q	n	Ca (kgf)	Coa (kgf)	
SFH01205-2.8 *	12	5	2.5	24	40	5	10	30	32	30	4.5		2.8x1	661	1316	19
SFH01210-2.8 *		10	2.5	24	40	5	10	45	32	30	4.5		2.8x1	642	1287	19
SFH01605-3.8 *	15	5	2.778	28	48	5	10	37	38	40	5.5	M6	3.8x1	1112	2507	30
SFH01610-2.8 *		10	2.778	28	48	5	10	45	38	40	5.5	M6	2.8x1	839	1821	23
SFH01616-1.8 *		16	2.778	28	48	5	10	45	38	40	5.5	M6	1.8x1	552	1137	14
SFH01616-2.8 *		16	2.778	28	48	5	10	61	38	40	5.5	M6	2.8x1	808	1769	22
SFH01620-1.8 *	20	20	2.778	28	48	7	10	58	38	40	5.5	M6	1.8x1	554	1170	14
SFH02005-3.8 *		5	3.175	36	58	7	10	37	47	44	6.6	M6	3.8x1	1484	3681	37
SFH02010-3.8 *		10	3.175	36	58	7	10	55	47	44	6.6	M6	3.8x1	1516	3833	40
SFH02020-1.8 *		20	3.175	36	58	7	10	54	47	44	6.6	M6	1.8x1	764	1758	19
SFH02020-2.8 *	25	20	3.175	36	58	7	10	74	47	44	6.6	M6	2.8x1	1118	2734	29
SFH02505-3.8 *		5	3.175	40	62	7	10	37	51	48	6.6	M6	3.8x1	1650	4658	43
SFH02510-3.8 *		10	3.175	40	62	7	12	55	51	48	6.6	M6	3.8x1	1638	4633	45
SFH02525-1.8 *		25	3.175	40	62	7	12	64	51	48	6.6	M6	1.8x1	843	2199	22
SFH02525-2.8 *	32	25	3.175	40	62	7	12	89	51	48	6.6	M6	2.8x1	1232	3421	34
SFH03205-3.8		5	3.175	50	80	9	12	37	65	62	9	M6	3.8x1	1839	6026	51
SFH03210-3.8		10	3.969	50	80	9	12	57	65	62	9	M6	3.8x1	2460	7255	55
SFH03220-2.8		20	3.969	50	80	9	12	76	65	62	9	M6	2.8x1	1907	5482	43
SFH03232-1.8	31	32	3.969	50	80	9	12	80	65	62	9	M6	1.8x1	1257	3426	27
SFH03232-2.8		32	3.969	50	80	9	12	112	65	62	9	M6	2.8x1	1838	5329	42
SFH04005-3.8	40	5	3.175	63	93	9	15	42	78	70	9	M8	3.8x1	2018	7589	60
SFH04010-3.8		10	6.35	63	93	9	14	60	78	70	9	M8	3.8x1	5035	13943	67
SFH04020-2.8		20	6.35	63	93	9	14	80	78	70	9	M8	2.8x1	3959	10715	54
SFH04040-1.8		40	6.35	63	93	9	14	98	78	70	9	M8	1.8x1	2585	6648	34
SFH04040-2.8	50	40	6.35	63	93	9	14	138	78	70	9	M8	2.8x1	3780	10341	52
SFH05005-3.8		5	3.175	75	110	10.5	15	42	93	85	11	M8	3.8x1	2207	9542	68
SFH05010-3.8		10	6.35	75	110	10.5	18	60	93	85	11	M8	3.8x1	5638	17852	79
SFH05020-3.8		20	6.35	75	110	10.5	18	100	93	85	11	M8	3.8x1	5749	18485	87
SFH05050-1.8	48	50	6.35	75	110	10.5	18	120	93	85	11	M8	1.8x1	2946	8749	42
SFH05050-2.8		50	6.35	75	110	10.5	18	170	93	85	11	M8	2.8x1	4308	13610	65

※ ★ Actuator type available (SFNH series).

SFA (DIN 69051 FORM B) Series Specifications

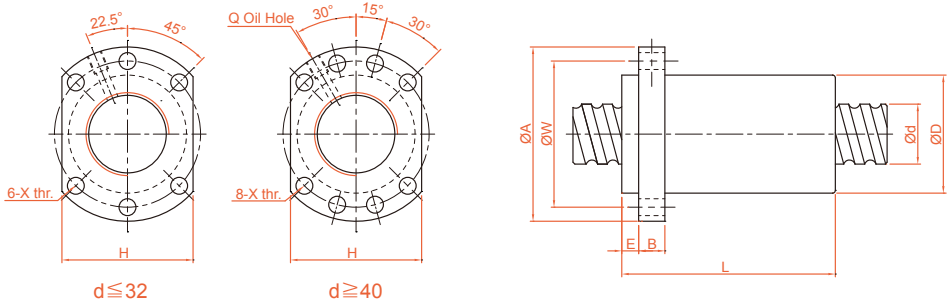

Unit : mm

Model No.	d	l	Da	Dimension										Load Rating		K kgf/μm
				D	A	E	B	L	W	H	X	Q	n	Ca (kgf)	Coa (kgf)	
SFA1205-2.8 *	12	5	2.5	24	40	5	10	30	32	30	4.5		2.8×1	661	1316	19
SFA1210-2.8 *		10	2.5	24	40	5	10	42	32	30	4.5		2.8×1	642	1287	19
SFA1605-3.8 *	15	5	2.778	28	48	5	10	31	38	40	5.5	M6	3.8×1	1112	2507	30
SFA1610-2.8 *		10	2.778	28	48	5	10	42	38	40	5.5	M6	2.8×1	839	1821	23
SFA1616-1.8 *		16	2.778	28	48	5	10	43	38	40	5.5	M6	1.8×1	552	1137	14
SFA1616-2.8 *		16	2.778	28	48	5	10	59	38	40	5.5	M6	2.8×1	808	1769	22
SFA1620-1.8 *		20	2.778	28	48	5	10	50	38	40	5.5	M6	1.8×1	554	1170	14
SFA1630-1.8 *		30	2.778	28	48	7	10	70	38	40	5.5	M6	1.8×1	534	1195	14
SFA2005-3.8 *	20	5	3.175	36	58	7	10	33	47	44	6.6	M6	3.8×1	1484	3681	37
SFA2010-3.8 *		10	3.175	36	58	7	10	52	47	44	6.6	M6	3.8×1	1516	3833	40
SFA2020-1.8 *		20	3.175	36	58	7	10	52	47	44	6.6	M6	1.8×1	764	1758	19
SFA2020-2.8 *		20	3.175	36	58	7	10	72	47	44	6.6	M6	2.8×1	1118	2734	29
SFA2505-3.8 *	25	5	3.175	40	62	7	10	33	51	48	6.6	M6	3.8×1	1650	4658	43
SFA2510-3.8 *		10	3.175	40	62	7	12	52	51	48	6.6	M6	3.8×1	1638	4633	45
SFA2525-1.8 *		25	3.175	40	62	7	12	60	51	48	6.6	M6	1.8×1	843	2199	22
SFA2525-2.8 *		25	3.175	40	62	7	12	85	51	48	6.6	M6	2.8×1	1232	3421	34
SFA3205-3.8	32	5	3.175	50	80	9	12	35	65	62	9	M6	3.8×1	1839	6026	51
SFA3210-3.8		10	3.969	50	80	9	12	53	65	62	9	M6	3.8×1	2460	7255	55
SFA3220-2.8	31	20	3.969	50	80	9	12	72	65	62	9	M6	2.8×1	1907	5482	43
SFA3232-1.8		32	3.969	50	80	9	12	78	65	62	9	M6	1.8×1	1257	3426	27
SFA3232-2.8		32	3.969	50	80	9	12	110	65	62	9	M6	2.8×1	1838	5329	42
SFA4005-3.8	40	5	3.175	63	93	9	14	39	78	70	9	M8	3.8×1	2018	7589	60
SFA4010-3.8		10	6.35	63	93	9	14	57	78	70	9	M8	3.8×1	5035	13943	67
SFA4020-2.8	38	20	6.35	63	93	9	14	78	78	70	9	M8	2.8×1	3959	10715	54
SFA4040-1.8		40	6.35	63	93	9	14	96	78	70	9	M8	1.8×1	2585	6648	34
SFA4040-2.8		40	6.35	63	93	9	14	136	78	70	9	M8	2.8×1	3780	10341	52
SFA5005-3.8	50	5	3.175	75	110	10.5	15	42	93	85	11	M8	3.8×1	2207	9542	68
SFA5010-3.8		10	6.35	75	110	10.5	18	57	93	85	11	M8	3.8×1	5638	17852	79
SFA5020-2.8		20	6.35	75	110	10.5	18	98	93	85	11	M8	3.8×1	5749	18485	87
SFA5050-1.8		50	6.35	75	110	10.5	18	117	93	85	11	M8	1.8×1	2946	8749	42
SFA5050-2.8		50	6.35	75	110	10.5	18	167	93	85	11	M8	2.8×1	4308	13610	65

※ ★ Actuator type available.

TBI MOTION BALL SCREW

2-2 Precision Ground Ball Screw Series

SFJ (DIN 69051 FORM B) Series Specifications

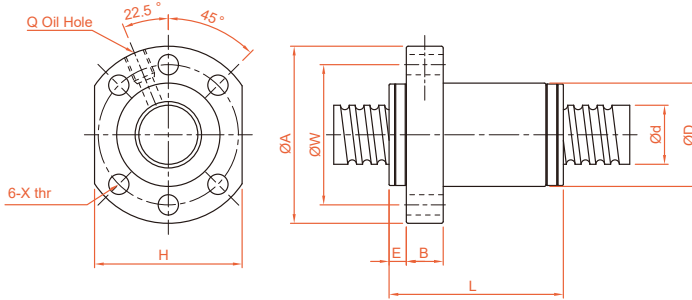

單位 : mm

Model No.	d	l	Da	Dimension										Load Rating		K kgf/ μ m
				D	A	E	B	L	W	H	X	Q	n	Ca (kgf)	Coa (kgf)	
SFJ00606-1.8	6	6	1.2	14	27	3	4	21	21	16	3.4	-	1.8x1	78	122	4
SFJ00808-1.8	8	8		18	31	3	4	26	25	20	3.4	-	1.8x1	89	164	5
SFJ01205-2.8	12	5	2.5	24	40	3.5	10	31	32	30	4.5	-	2.8x1	418	753	12
SFJ01210-2.8		10		24	40	4.7	10	48.5	32	30	4.5	-	2.8x1	405	752	12
SFJ01605-3.8	15	5	2.778	28	48	4	10	38	38	40	5.5	M6x1	3.8x1	706	1472	20
SFJ01610-2.8		10		28	48	4.7	10	48	38	40	5.5	M6x1	2.8x1	532	1082	15
SFJ01616-1.8		16		28	48	4	10	45.5	38	40	5.5	M6x1	1.8x1	364	693	10
SFJ01620-1.8		20		28	48	4.7	10	56.5	38	40	5.5	M6x1	1.8x1	351	696	10
SFJ02005-3.8	20	5	3.175	36	58	6	10	40	47	44	6.6	M6x1	3.8x1	975	2293	25
SFJ02010-3.8		10		36	58	4	10	57	47	44	6.6	M6x1	3.8x1	996	2302	27
SFJ02020-1.8		20		36	58	4	10	57	47	44	6.6	M6x1	1.8x1	503	1056	12
SFJ02505-3.8	25	5	3.175	40	62	6	10	40	51	48	6.6	M6x1	3.8x1	1084	2879	30
SFJ02510-3.8		10		40	62	5.5	12	62	51	48	6.6	M6x1	3.8x1	1076	2863	31
SFJ02525-1.8		25		40	62	6	12	70	51	48	6.6	M6x1	1.8x1	554	1351	15

SCNH Series Specifications

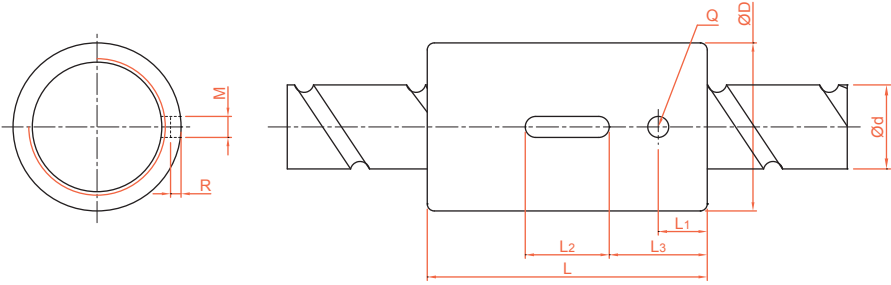

Unit : mm

Model No.	d	l	Da	Dimension									Load Rating		K kgf/μm
				D	L	L1	L2	L3	M	R	Q	n	Ca (kgf)	Coa (kgf)	
SCNH01205-4.8	12	5	2.5	24	40	7	12	14	3	1.5	3	4.8x1	1011	2105	34
SCNH01210-2.8		10	2.5	24	45	8	15	15	3	1.5	3	2.8x1	642	1287	19
XCNH01210-1.8		10	2.5	24	40	10.5	12	14	3	1.5	3	1.8x1	439	827	33
SCNH01605-5.8	15	5	2.778	28	45	7	20	12.5	5	3	3	5.8x1	1599	3827	49
SCNH01610-2.8		10	2.778	28	45	7	20	12.5	5	3	3	2.8x1	839	1821	23
SCNH01616-1.8		16	2.778	28	45	7	20	12.5	5	3	3	1.8x1	552	1137	18
SCNH01620-1.8		20	2.778	28	58	10	20	19	5	3	3	1.8x1	554	1170	14
SCNH02005-5.8	20	5	3.175	36	47	8	20	13.5	5	3	3	5.8x1	2134	5619	60
SCNH02010-3.8		10	3.175	36	55	8	20	17.5	5	3	3	3.8x1	1516	3833	40
SCNH02020-1.8		20	3.175	36	55	8	20	17.5	5	3	3	1.8x1	764	1758	19

TBI MOTION BALL SCREW

2-2 Precision Ground Ball Screw Series

SFNU/SFU (DIN 69051 FORM B) Series Specifications

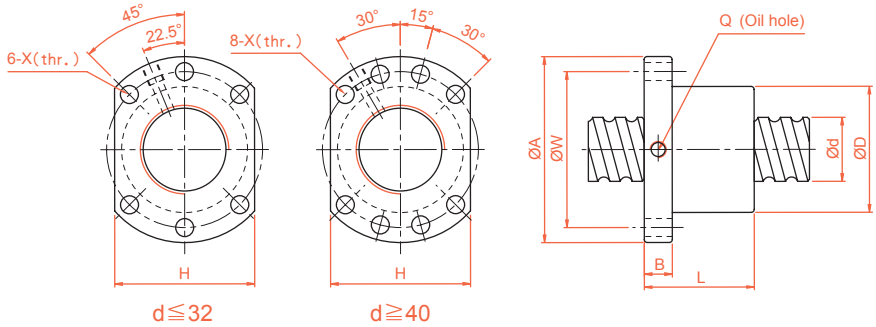

Unit : mm

Model No.	d	l	Da	Dimension									Load Rating		K kgf/μm
				D	A	B	L	W	H	X	Q	n	Ca (kgf)	Coa (kgf)	
SFNU01605-4*	16	5	3.175	28	48	10	45	38	40	5.5	M6	1x4	1380	3052	32
SFNU01610-3*		10	3.175	28	48	10	57	38	40	5.5	M6	1x3	1103	2401	26
SFNU02005-4*	20	5	3.175	36	58	10	51	47	44	6.6	M6	1x4	1551	3875	39
SFNU02505-4*	25	5	3.175	40	62	10	51	51	48	6.6	M6	1x4	1724	4904	45
SFNU02510-4*		10	4.762	40	62	12	80	51	48	6.6	M6	1x4	2954	7295	50
SFNU03205-4*	32	5	3.175	50	80	12	52	65	62	9	M6	1x4	1922	6343	54
SFNU03210-4*		10	6.35	50	80	12	85	65	62	9	M6	1x4	4805	12208	61
SFNU04005-4*	40	5	3.175	63	93	14	55	78	70	9	M8	1x4	2110	7988	63
SFNU04010-4*		10	6.35	63	93	14	88	78	70	9	M8	1x4	5399	15500	73
SFNU05010-4*	50	10	6.35	75	110	16	88	93	85	11	M8	1x4	6004	19614	85
SFNU05020-4	50	20	7.144	75	110	16	138	93	85	11	M8	1x4	7142	22588	94
SFNU06310-4	63	10	6.35	90	125	18	93	108	95	11	M8	1x4	6719	25358	99
SFNU06320-4	63	20	9.525	95	135	20	149	115	100	13.5	M8	1x4	11444	36653	112
SFNU08010-4	80	10	6.35	105	145	20	93	125	110	13.5	M8	1x4	7346	31953	109
SFNU08020-4	80	20	9.525	125	165	25	154	145	130	13.5	M8	1x4	12911	47747	138
SFU01204-4	12	4	2.5	24	40	10	40	32	30	4.5		1x4	902	1884	26
SFU01604-4	16	4	2.381	28	48	10	40	38	40	5.5	M6	1x4	973	2406	32
SFU02004-4	20	4	2.381	36	58	10	42	47	44	6.6	M6	1x4	1066	2987	38
SFU02504-4	25	4	2.381	40	62	10	42	51	48	6.6	M6	1x4	1180	3795	43
SFU02506-4		6	3.969	40	62	10	54	51	48	6.6	M6	1x4	2318	6057	47
SFU02508-4		8	4.762	40	62	10	63	51	48	6.6	M6	1x4	2963	7313	49
SFU03204-4	32	4	2.381	50	80	12	44	65	62	9	M6	1x4	1296	4838	51
SFU03206-4		6	3.969	50	80	12	57	65	62	9	M6	1x4	2632	7979	57
SFU03208-4		8	4.762	50	80	12	65	65	62	9	M6	1x4	3387	9622	60
SFU04006-4	40	6	3.969	63	93	14	60	78	70	9	M6	1x4	2873	9913	66
SFU04008-4		8	4.762	63	93	14	67	78	70	9	M6	1x4	3712	11947	70
SFU10020-4	100	20	9.525	150	202	30	180	170	155	17.5	M8	1x4	14303	60698	162

※ ☆ Left helix available ※ Standard ball nut SFU01204-4 is assembled without wiper.

OFU (DIN 69051 FORM B) Series Specifications

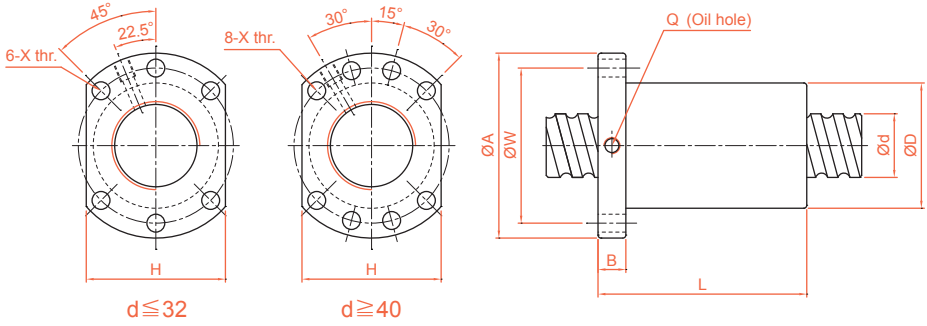

Unit : mm

Model No.	d	l	Da	Dimension									Load Rating		K kgf/μm
				D	A	B	L	W	H	X	Q	n	Ca (kgf)	Coa (kgf)	
OFU01605-4	16	5	3.175	28	48	10	75	38	40	5.5	M6	1x4	1380	3052	44
OFU02005-4	20	5	3.175	36	58	10	85	47	44	6.6	M6	1x4	1551	3875	53
OFU02505-4	25	5	3.175	40	62	10	86	51	48	6.6	M6	1x4	1724	4904	62
OFU02510-4		10	4.762	40	62	12	130	51	48	6.6	M6	1x4	2954	7295	67
OFU03205-4	32	5	3.175	50	80	12	87	65	62	9	M6	1x4	1922	6343	74
OFU03210-4		10	6.35	50	80	12	145	65	62	9	M6	1x4	4805	12208	82
OFU04005-4	40	5	3.175	63	93	14	90	78	70	9	M8	1x4	2110	7988	87
OFU04010-4		10	6.35	63	93	14	148	78	70	9	M8	1x4	5399	15500	99
OFU05010-4	50	10	6.35	75	110	16	148	93	85	11	M8	1x4	6004	19614	117
OFU06310-4	63	10	6.35	90	125	18	153	108	95	11	M8	1x4	6719	25358	139
OFU08010-4	80	10	6.35	105	145	20	153	125	110	13.5	M8	1x4	7346	31953	156

TBI MOTION BALL SCREW

2-2 Precision Ground Ball Screw Series

SFNI/SFI Series Specifications

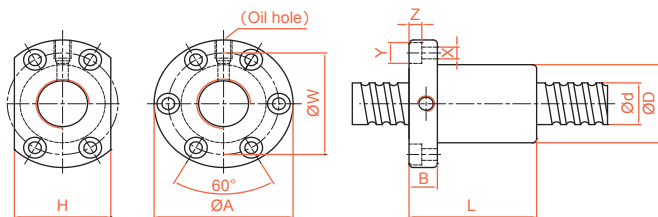

Unit : mm

Model No.	d	l	Da	Dimension											Load Rating		K kgf/μm
				D	A	B	L	W	H	X	Y	Z	Q	n	Ca (kgf)	Coa (kgf)	
SFNI01605-4*	16	5	3.175	30	49	10	45	39	34	4.5	8	4.5	M6	1x4	1380	3052	33
SFNI01610-3*		10	3.175	34	58	10	57	45	34	5.5	9.5	5.5	M6	1x3	1103	2401	27
SFNI02005-4*	20	5	3.175	34	57	11	51	45	40	5.5	9.5	5.5	M6	1x4	1551	3875	39
SFNI02505-4*		5	3.175	40	63	11	51	51	46	5.5	9.5	5.5	M8	1x4	1724	4904	45
SFNI02510-4*	25	10	4.762	46	72	12	80	58	52	6.5	11	6.5	M6	1x4	2954	7295	51
SFNI03205-4*		5	3.175	46	72	12	52	58	52	6.5	11	6.5	M8	1x4	1922	6343	52
SFNI03210-4*	32	10	6.35	54	88	15	85	70	62	9	14	8.5	M8	1x4	4805	12208	62
SFNI04005-4*		5	3.175	56	90	15	55	72	64	9	14	8.5	M8	1x4	2110	7988	59
SFNI04010-4*	40	10	6.35	62	104	18	88	82	70	11	17.5	11	M8	1x4	5399	15500	72
SFNI05010-4*		50	10	6.35	72	114	18	88	92	82	11	17.5	11	M8	1x4	6004	19614
SFNI06310-4	63	10	6.35	85	131	22	93	107	95	14	20	13	M8	1x4	6719	25358	95
SFNI08010-4		80	10	6.35	105	150	22	93	127	115	14	20	13	M8	1x4	7346	31953
SFI01604-4	16	4	2.381	30	49	10	45	39	34	4.5	8	4.5	M6	1x4	973	2406	32
SFI02004-4		4	2.381	34	57	11	46	45	40	5.5	9.5	5.5	M6	1x4	1066	2987	37
SFI0205T-4	20	5.08	3.175	34	57	11	51	45	40	5.5	9.5	5.5	M6	1x4	1550	3875	39
SFI02504-4*		4	2.381	40	63	11	46	51	46	5.5	9.5	5.5	M6	1x4	1180	3795	43
SFI0255T-4	25	5.08	3.175	40	63	11	51	51	46	5.5	9.5	5.5	M8	1x4	1724	4903	45
SFI03204-4		32	4	2.381	46	72	12	47	58	52	6.5	11	6.5	M6	1x4	1296	4838

SFM Series Specifications

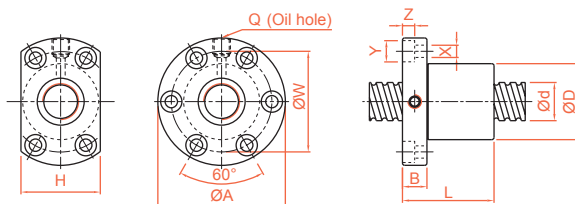

Unit : mm

Model No.	d	l	Da	Dimension											Load Rating		K kgf/μm
				D	A	B	L	W	H	X	Y	Z	Q	n	Ca (kgf)	Coa (kgf)	
SFM03205-4*	32	5	3.175	48	74	12	52	60	60	6.5	11	6.5	M8	1x4	1922	6343	53
SFM0325T-4*		5.08	3.175	48	74	12	53	60	60	6.5	11	6.5	M8	1x4	1922	6343	53

* Left helix available

OFI Series Specifications

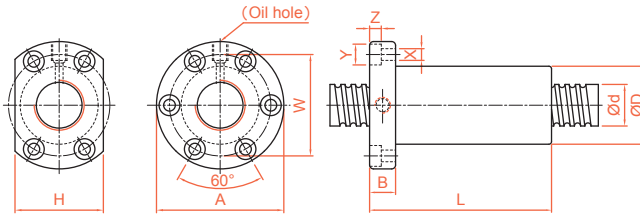

Unit : mm

ModelNo.	d	l	Da	Dimension											LoadRating		K kgf/μm
				D	A	B	L	W	H	X	Y	Z	Q	n	Ca (kgf)	Coa (kgf)	
OFI01605-4	16	5	3.175	30	49	10	75	39	34	4.5	8	4.5	M6	1x4	1380	3052	44
OFI02005-4	20	5	3.175	34	57	11	85	45	40	5.5	9.5	5.5	M6	1x4	1551	3875	52
OFI02505-4	25	5	3.175	40	63	11	86	51	46	5.5	9.5	5.5	M8	1x4	1724	4904	62
OFI02510-4		10	4.762	46	72	12	130	58	52	6.5	11	6.5	M6	1x4	2954	7295	68
OFI03205-4	32	5	3.175	46	72	12	87	58	52	6.5	11	6.5	M8	1x4	1922	6343	72
OFI03210-4		10	6.35	54	88	15	145	70	62	9	14	8.5	M8	1x4	4805	12208	83
OFI04005-4	40	5	3.175	56	90	15	90	72	64	9	14	8.5	M8	1x4	2110	7988	84
OFI04010-4		10	6.35	62	104	18	148	82	70	11	17.5	11	M8	1x4	5399	15500	99
OFI05010-4	50	10	6.35	72	114	18	148	92	82	11	17.5	11	M8	1x4	6004	19614	115
OFI06310-4	63	10	6.35	85	131	22	153	107	95	14	20	13	M8	1x4	6719	25358	135
OFI08010-4	80	10	6.35	105	150	22	153	127	115	14	20	13	M8	1x4	7346	31953	156

C

Ball Screw

TBI MOTION BALL SCREW

2-2 Precision Ground Ball Screw Series

SFV Series Specifications

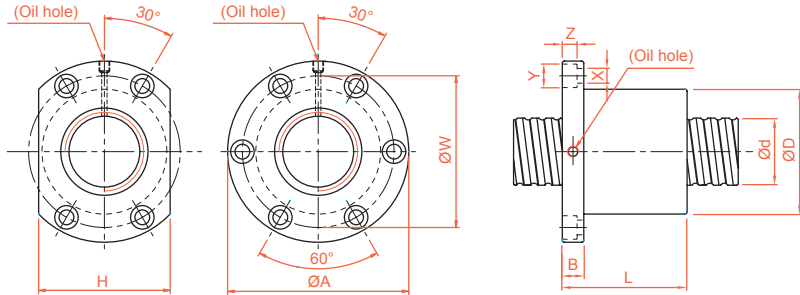

Unit : mm

Model No.	d	l	Da	Dimension											Load Rating		K kgf/µm
				D	A	B	L	W	H	X	Y	Z	Q	n	Ca (kgf)	Coa (kgf)	
SFV01205-2.8	12	5	2.5	30	50	10	42	40	32	4.5	8	4.5	M6	2.8x1	661	1316	19
SFV01210-2.7		10	2.5	30	50	10	53	40	32	4.5	8	4.5	M6	2.7x1	623	1241	18
SFV01510-2.7	15	10	3.175	34	58	10	57	45	34	5.5	9.5	5.5	M6	2.7x1	972	2020	23
SFV01604-3.8	16	4	2.381	34	57	11	45	45	34	5.5	9.5	5.5	M6	3.8x1	931	2285	31
SFV01605-4.8		5	3.175	40	63	11	58	51	42	5.5	9.5	5.5	M6	4.8x1	1614	3662	40
SFV01610-2.7	20	10	3.175	40	63	11	56	51	42	5.5	9.5	5.5	M6	2.7x1	1008	2161	24
SFV02004-4.8		4	2.381	40	60	10	50	50	40	4.5	8	4	M6	4.8x1	1247	3584	45
SFV02005-4.8	20	5	3.175	44	67	11	57	55	52	5.5	9.5	5.5	M6	4.8x1	1814	4650	47
SFV02010-2.7		10	3.969	46	74	13	57	59	46	6.6	11	6.5	M6	2.7x1	1518	3398	30
SFV02020-1.8	25	20	3.175	46	74	13	70	59	46	6.6	11	6.5	M6	1.8x1	764	1758	19
SFV02050-4.8		5	3.175	50	73	11	55	61	52	5.5	9.5	5.5	M8	4.8x1	2017	5884	56
SFV02506-4.8	25	6	3.969	53	76	11	62	64	58	5.5	9.5	5.5	M6	4.8x1	2711	7268	58
SFV02508-4.8		8	4.762	56	85	13	70	71	64	6.5	11	6.5	M6	4.8x1	3466	8776	61
SFV02510-2.7	32	10	6.35	68	102	15	70	84	82	9	14	8.5	M8	2.7x1	3040	6547	37
SFV02525-1.8		25	3.175	50	73	13	83	61	52	5.5	9.5	5.5	M8	1.8x1	843	2199	22
SFV03204-4.8	32	4	2.381	54	81	12	50	67	64	6.6	11	6.5	M6	4.8x1	1517	5806	62
SFV03205-4.8		5	3.175	58	85	12	56	71	64	6.6	11	6.5	M8	4.8x1	2249	7612	66
SFV03206-4.8	32	6	3.969	62	89	12	60	75	68	6.6	11	6.5	M8	4.8x1	3079	9575	70
SFV03208-4.8		8	4.762	66	100	15	75	82	76	9	14	8.5	M8	4.8x1	3962	11547	74
SFV03210-4.8	40	10	6.35	74	108	15	96	90	82	9	14	9	M8	4.8x1	5620	14649	76
SFV03220-2.7		20	6.35	74	108	16	100	90	82	9	14	8.5	M8	2.7x1	3509	8644	46
SFV04005-4.8	40	5	3.175	67	101	15	59	83	72	9	14	8.5	M8	4.8x1	2468	9586	76
SFV04010-4.8		10	6.35	82	124	18	100	102	94	11	17.5	11	M8	4.8x1	6316	18600	90
SFV04020-2.7	50	20	6.35	82	124	18	100	102	90	11	17.5	11	M8	2.7x1	3935	10893	56
SFV05005-4.8		5	3.175	80	114	15	60	96	82	9	14	8.5	M8	4.8x1	2698	12053	87
SFV05010-4.8	50	10	6.35	93	135	16	93	113	98	11	17.5	11	M8	4.8x1	7023	23537	106
SFV05020-2.7		20	9.525	105	152	28	121	128	110	14	20	13	M8	2.7x1	7336	19700	68
SFV06310-4.8	63	10	6.35	108	154	22	105	130	110	14	20	13	M8	4.8x1	7860	30430	126
SFV06320-2.7		20	9.525	122	180	28	120	150	130	18	26	17.5	M8	2.7x1	8162	24741	80
SFV08010-4.8	80	10	6.35	130	176	22	105	152	132	14	20	13	M8	4.8x1	8593	38344	145
SFV08020-4.8		20	9.525	143	204	28	180	172	148	18	26	18	M8	4.8x1	15103	57296	168
SFV08020-7.6	20	9.525	143	204	28	240	172	148	18	26	18	M8	3.8x2	22423	90719	260	

OFV Series Specifications

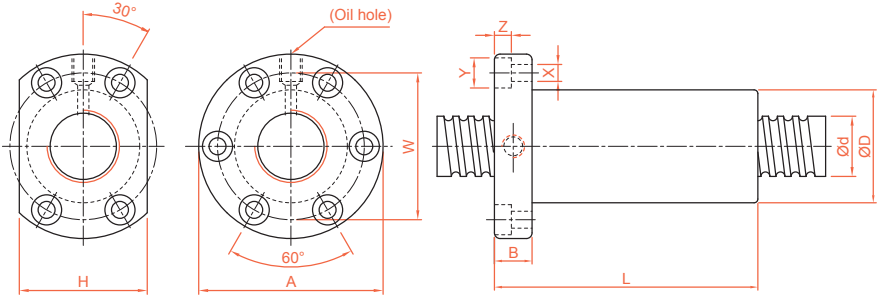

Unit : mm

Model No.	d	l	Da	Dimension											Load Rating		K kgf/μm
				D	A	B	L	W	H	X	Y	Z	Q	n	Ca (kgf)	Coa (kgf)	
OFV01605-4.8	16	5	3.175	40	63	11	100	51	42	5.5	9.5	5.5	M6	4.8x1	1614	3662	53
OFV02005-4.8	20	5	3.175	44	67	11	102.5	55	52	5.5	9.5	5.5	M6	4.8x1	1814	4650	63
OFV02505-4.8	25	5	3.175	50	73	11	96	61	52	5.5	9.5	5.5	M8	4.8x1	2017	5884	75
OFV03205-4.8	32	5	3.175	58	85	12	98	71	64	6.6	11	6.5	M8	4.8x1	2249	7612	90
OFV03210-4.8		10	6.35	74	108	15	166	90	82	9	14	9	M8	4.8x1	5620	14649	101
OFV04005-4.8	40	5	3.175	67	101	15	100	83	72	9	14	8.5	M8	4.8x1	2468	9586	105
OFV04010-4.8		10	6.35	82	124	18	174	102	94	11	17.5	11	M8	4.8x1	6316	18600	121
OFV05010-4.8	50	10	6.35	93	135	16	167	113	98	11	17.5	11	M8	4.8x1	7023	23537	144
OFV06310-4.8	63	10	6.35	108	154	22	177	130	110	14	20	13	M8	4.8x1	7860	30430	172
OFV08010-4.8	80	10	6.35	130	176	22	178	152	132	14	20	13	M8	4.8x1	8593	38344	201

Note : For double ball screw nut order, please contact **TBI MOTION** in advance.

TBI MOTION BALL SCREW

2-2 Precision Ground Ball Screw Series

SFY Series Specifications

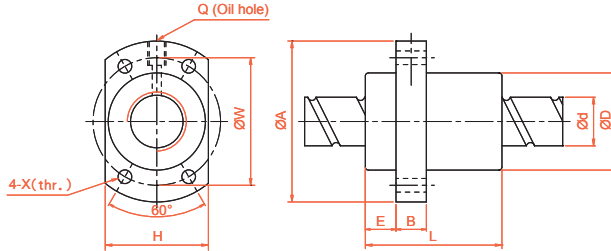

Unit : mm

Large Lead Model No.	d	l	Da	Dimension										Load Rating		K kgf/μm
				D	A	E	B	L	W	H	X	Q	n	Ca (kgf)	Coa (kgf)	
SFY01616-3.6	16	16	2.778	32	53	10.1	10	45	42	34	4.5	M6	1.8x2	1073	2551	31
SFY01616-5.6		16	2.778	32	53	10.1	10	61	42	34	4.5	M6	2.8x2	1568	3968	47
SFY02020-3.6	20	20	3.175	39	62	13	10	52	50	41	5.5	M6	1.8x2	1387	3515	37
SFY02020-5.6		20	3.175	39	62	13	10	72	50	41	5.5	M6	2.8x2	2029	5468	56
SFY02525-3.6	25	25	3.969	47	74	15	12	64	60	49	6.6	M6	1.8x2	2074	5494	45
SFY02525-5.6		25	3.969	47	74	15	12	89	60	49	6.6	M6	2.8x2	3032	8546	69
SFY03232-3.6	32	32	4.762	58	92	17	12	78	74	60	9	M6	1.8x2	3021	8690	58
SFY03232-5.6		32	4.762	58	92	17	12	110	74	60	9	M6	2.8x2	4417	13517	88
SFY04040-3.6	40	40	6.35	73	114	19.5	15	99	93	75	11	M6	1.8x2	4831	14062	70
SFY04040-5.6		40	6.35	73	114	19.5	15	139	93	75	11	M6	2.8x2	7065	21874	106
SFY05050-3.6	50	50	7.938	90	135	21.5	20	117	112	92	14	M6	1.8x2	7220	21974	86
SFY05050-5.6		50	7.938	90	135	21.5	20	167	112	92	14	M6	2.8x2	10558	34182	131
Twin Lead Model No.	d	l	Da	Dimension										Ca (kgf)	Coa (kgf)	K kgf/μm
SFY01632-1.6	16	32	2.778	32	53	10.1	10	42.5	42	34	4.5	M6	0.8x2	493	1116	11
SFY01632-3.6		32	2.778	32	53	10.1	10	74.5	42	34	4.5	M6	1.8x2	989	2511	23
SFY02040-1.6	20	40	3.175	39	62	13	10	48	50	41	5.5	M6	0.8x2	653	1597	15
SFY02040-3.6		40	3.175	39	62	13	10	88	50	41	5.5	M6	1.8x2	1311	3592	30
SFY02550-1.6	25	50	3.969	47	74	15	12	58	60	49	6.6	M6	0.8x2	976	2495	19
SFY02550-3.6		50	3.969	47	74	15	12	108	60	49	6.6	M6	1.8x2	1960	5614	32
SFY03264-1.6	32	64	4.762	58	92	17	12	71	74	60	9	M6	0.8x2	1374	3571	22
SFY03264-3.6		64	4.762	58	92	17	12	135	74	60	9	M6	1.8x2	2759	8441	46
SFY04080-1.6	40	80	6.35	73	114	19.5	15	90	93	75	11	M6	0.8x2	2273	6387	29
SFY04080-3.6		80	6.35	73	114	19.5	15	170	93	75	11	M6	1.8x2	4566	14370	50
SFY050100-1.6	50	100	7.938	90	135	21.5	20	111	112	92	14	M6	0.8x2	3398	9980	35
SFY050100-3.6		100	7.938	90	135	21.5	20	211	112	92	14	M6	1.8x2	6824	22455	72

SFYA Series Specifications

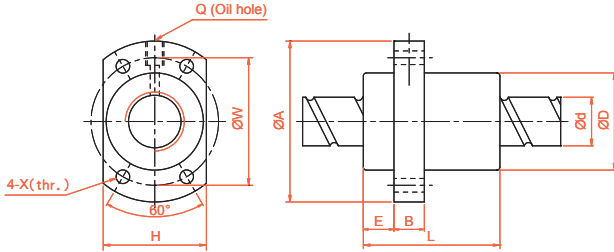

單位 : mm

Large Lead Model No.	d	l	Da	Dimension										Load Rating		K kgf/ µm
				D	A	E	B	L	W	H	X	Q	n	Ca (kgf)	Coa (kgf)	
SFYA01616-3.6	16	16	2.778	32	53	10.1	10	45	42	34	4.5	M6	1.8*2	1073	2551	31
SFYA02020-3.6	20	20	3.175	39	62	13	10	52	50	41	5.5	M6	1.8*2	1387	3515	37
SFYA02525-3.6	25	25	3.969	47	74	15	12	64	60	49	6.6	M6	1.8*2	2074	5494	45
SFYA03232-3.6	32	32	4.762	58	92	17	12	78	74	60	9	M6	1.8*2	3021	8690	58
SFYA04040-3.6	40	40	6.35	73	114	19.5	15	99	93	75	11	M6	1.8*2	4831	14062	70
SFYA05050-3.6	50	50	7.938	90	135	21.5	20	117	112	92	14	M6	1.8*2	7220	21974	86
Twin Lead Model No.	d	l	Da	Dimension										Ca (kgf)	Coa (kgf)	K kgf/ µm
				D	A	E	B	L	W	H	X	Q	n			
SFYA01632-1.6	16	32	2.778	32	53	10.1	10	42.5	42	34	4.5	M6	0.8*2	493	1116	11
SFYA02040-1.6	20	40	3.175	39	62	13	10	48	50	41	5.5	M6	0.8*2	653	1597	15
SFYA02550-1.6	25	50	3.969	47	74	15	12	58	60	49	6.6	M6	0.8*2	976	2495	19
SFYA03264-1.6	32	64	4.762	58	92	17	12	71	74	60	9	M6	0.8*2	1374	3571	22
SFYA04080-1.6	40	80	6.35	73	114	19.5	15	90	93	75	11	M6	0.8*2	2273	6387	29
SFYA050100-1.6	50	100	7.938	90	135	21.5	20	111	112	92	14	M6	0.8*2	3398	9980	35

TBI MOTION BALL SCREW

2-2 Precision Ground Ball Screw Series

SCNI/SCI Series Specifications

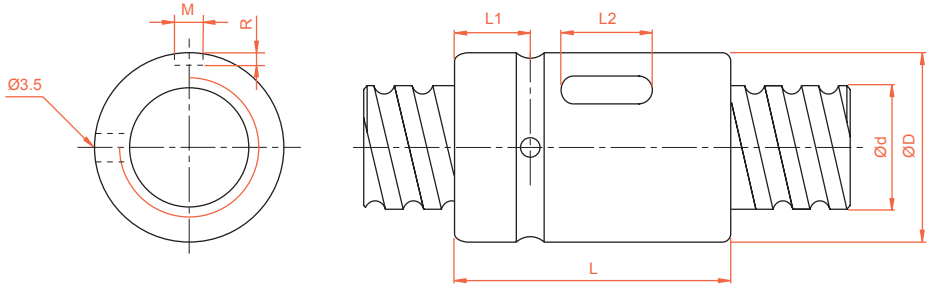

Unit : mm

Model No.	d	l	Da	Dimension							Load Rating		K kgf/μm
				D	L	L1	L2	M	R	n	Ca (kgf)	Coa (kgf)	
SCNI 01605-4	16	5	3.175	30	45	9	20	5	3	1x4	1380	3052	33
SCNI 02005-4	20	5	3.175	34	45	9	20	5	3	1x4	1551	3875	39
SCNI 02505-4	25	5	3.175	40	45	9	20	5	3	1x4	1724	4904	45
SCNI 02510-4		10	4.762	46	85	13	30	5	3	1x4	2954	7295	51
SCNI 03205-4	32	5	3.175	46	45	9	20	5	3	1x4	1922	6343	52
SCNI 03210-4		10	6.35	54	85	13	30	5	3	1x4	4805	12208	62
SCNI 04005-4	40	5	3.175	56	45	9	20	5	3	1x4	2110	7988	59
SCNI 04010-4		10	6.35	62	85	13	30	5	3	1x4	5399	15500	72
SCNI 05010-4	50	10	6.35	72	85	13	30	5	3	1x4	6004	19614	83
SCNI 06310-4	63	10	6.35	85	85	13	30	6	3.5	1x4	6719	25358	95
SCNI 08010-4	80	10	6.35	105	85	13	30	8	4.5	1x4	7346	31953	109
SCI 01604-4	16	4	2.381	30	40	9	15	3	1.5	1x4	973	2406	32
SCI 02004-4	20	4	2.381	34	40	9	15	3	1.5	1x4	1066	2987	37
SCI 02504-4	25	4	2.381	40	40	9	15	3	1.5	1x4	1180	3795	43
SCI 03204-4	32	4	2.381	46	40	9	15	3	1.5	1x4	1296	4838	49

SFK Series Specifications

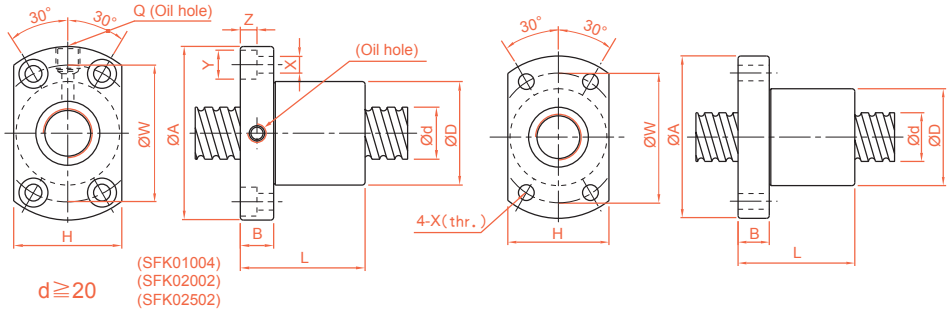

Unit : mm

Model No.	d	l	Da	Dimension											Ca (kgf)	Coa (kgf)	K (kgf/ μ m)
				D	A	B	L	W	H	X	Y	Z	Q	n			
SFK00401	4	1	0.8	10	20	3	12	15	14	2.9	-	-	-	1x2	64	97	5
SFK00601	6	1	0.8	12	24	3.5	15	18	16	3.4	-	-	-	1x3	111	224	9
SFK00801*	8	1	0.8	14	27	4	16	21	18	3.4	-	-	-	1x4	161	403	14
SFK00802*		2	1.2	14	27	4	18	21	18	3.4	-	-	-	1x3	222	458	13
SFK0082.5		2.5	1.2	16	29	4	26	23	20	3.4	-	-	-	1x3	221	457	13
SFK01002*	10	2	1.2	18	35	5	28	27	22	4.5	-	-	-	1x3	243	569	15
SFK01004		4	2	20	37	6	34	29	28	4.5	-	-	-	1x3	468	905	17
SFK01202*	12	2	1.2	20	37	5	28	29	24	4.5	-	-	-	1x4	334	906	22
SFK01205		5	2.5	22	37	8	39	29	24	4.5	-	-	-	1x3	702	1409	17
SFK01402*	14	2	1.2	21	40	6	23	31	26	5.5	-	-	-	1x4	354	1053	24
SFK01404		4	2.5	25	42	10	45	35	29	4.5	-	-	-	1x4	957	2155	16
SFK01602*	16	2	1.2	25	42	10	40	35	29	5.5	-	-	M6x1	1x4	373	1200	26
SFK2002	20	2	1.2	50	80	15	55	65	68	6.5	10.5	6	M6x1	1x6	581	2284	48
SFK2502	25	2	1.2	50	80	13	43	65	68	6.5	10.5	6	M6x1	1x5	540	2381	46
XSFK01004	10	4	2	26	46	10	34	36	28	4.5	8	4.5	M6x1	1x3	468	905	17
XSFK01404	14	4	2.5	26	46	10	45	36	28	4.5	8	4.5	M6x1	1x4	957	2145	16

※ ★ Left helix available

※ Standard ball nut SFK00401 is without wiper, other type K standard ball nut is available for with or without wiper, please contact TBI sales representatives.

Unit : mm

Model No.	d	l	Da	Dimension											Ca (kgf)	Coa (kgf)	K (kgf/ μ m)
				D	A	B	L	W	H	X	Y	Z	Q	n			
XSUR01204T3D-02	12	4	2.5	24	40	6	28	32	25	3.5	-	-	-	1x3	704	1413	-

※ Standard ball nut XSUR01204T3D-02 is assembled without wiper.

TBI MOTION BALL SCREW

2-2 Precision Ground Ball Screw Series

BSH Series Specifications

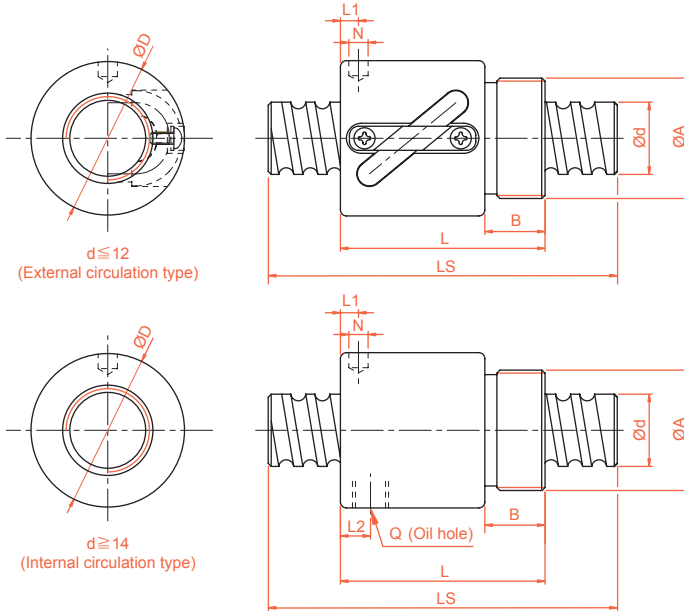

Unit : mm

Model No.	d	l	Da	Dimension									Ca (kgf)	Coa (kgf)	K kgf/ μ m
				D	A	B	L	L1	N	L2	Q	n			
BSHR0082.5-2.5	8	2.5	1.2	17.5	M15x1P	7.5	23.5	10	3	-	-	2.5x1	189	381	11
BSHR01002-3.5	10	2	1.2	19.5	M17x1P	7.5	22	3	3.2	-	-	3.5x1	277	664	17
BSHR01004-2.5		4	2	25	M20x1P	10	34	3	3	-	-	2.5x1	400	754	14
BSHR01204-3.5	12	4	2.5	25.5	M20x1P	10	34	13	3	-	-	3.5x1	804	1649	23
BSHR01205-3.5		5	2.5	25.5	M20x1P	10	39	16.25	3	-	-	3.5x1	801	1644	24
BSHR01404-3	14	4	2.5	32.1	M25x1.5P	10	35	11	3	-	-	1x3	748	1609	26
BSHR01604-3	16	4	2.381	29	M22x1.5P	8	32	4	3.2	-	-	1x3	759	1804	24
BSHR01605-3		5	3.175	32.5	M26x1.5P	12	42	19.25	3	-	-	1x3	1077	2289	25
BSHR01610-2		10	3.175	32	M26x1.5P	12	50	3	4	3	M4	1x2	779	1601	14
BSHR02005-3	20	5	3.175	38	M35x1.5P	15	45	20.3	3	-	-	1x3	1211	2906	30
BSHR02505-4	25	5	3.175	43	M40x1.5P	19	69	32.11	3	8	M6	1x4	1724	4904	37
BSHR02510-4		10	4.762	43	M40x1.5P	19	84	8	6	8	M6	1x4	2954	7295	41

※ Standard ball nut from $\varnothing 8$ - $\varnothing 16$ is assembled without wiper.

XSVR01210-01 Series Specifications (Finish Shaft Ends)

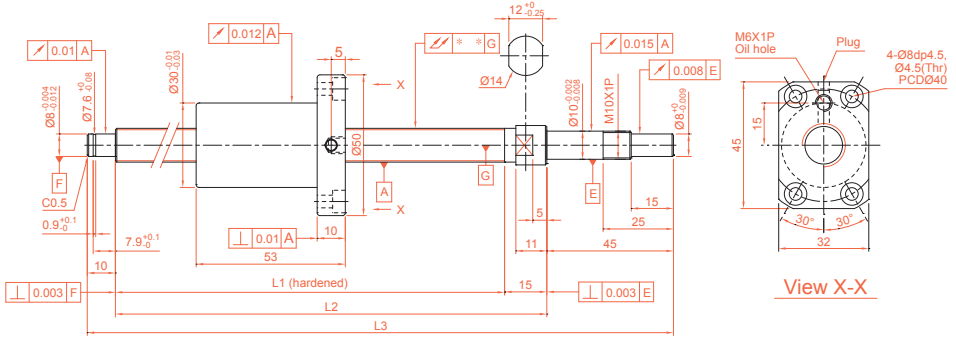

BCD	12.85
Ball Dia (mm)	2.5
Lead (mm)	10
No. of Turns	2.7x1
Lead Angle	13.91°
Threading Direction	R
Spring Force (kg)	0.1~0.2
Preload (kgf)	25
Dynamic Load Rating Ca (kgf)	411
Static Load Rating Coa (kgf)	638
Accuracy Grade	0.018

Unit : mm

Travel Length (mm)	Model No.	Shaft Length (mm)			Slant of Axle Center ∠
		L1	L2	L3	
100	XSVR01210B1DGC5-230-P1	160	175	230	0.035
150	XSVR01210B1DGC5-280-P1	210	225	280	0.035
250	XSVR01210B1DGC5-380-P1	310	325	380	0.050
350	XSVR01210B1DGC5-480-P1	410	425	480	0.060
450	XSVR01210B1DGC5-580-P1	510	525	580	0.075

TBI MOTION BALL SCREW

2-2 Precision Ground Ball Screw Series

XSVR01510-00 Series Specifications (Finish Shaft Ends)

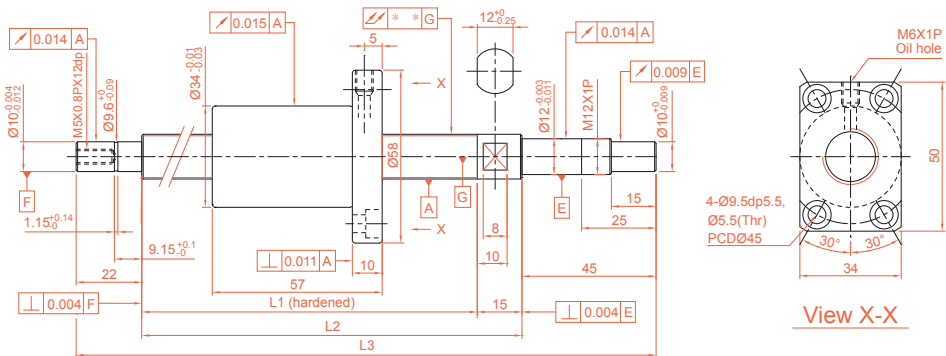

BCD	15.5
Ball Dia (mm)	3.175
Lead (mm)	10
No. of Turns	2.7x1
Lead Angle	11.6°
Threading Direction	R
Spring Force (kg)	0.1~0.3
Preload (kgf)	38
Dynamic Load Rating Ca (kgf)	611
Static Load Rating Coa (kgf)	950
Accuracy Grade	0.018

Unit : mm

Travel Length (mm)	Model No.	Shaft Length (mm)			Slant of Axle Center
		L1	L2	L3	∕∕
100	XSVR01510B1DGC5-271-P1	189	204	271	0.025
150	XSVR01510B1DGC5-321-P1	239	254	321	0.035
200	XSVR01510B1DGC5-371-P1	289	304	371	0.035
250	XSVR01510B1DGC5-421-P1	339	354	421	0.040
300	XSVR01510B1DGC5-471-P1	389	404	471	0.040
350	XSVR01510B1DGC5-521-P1	439	454	521	0.050
400	XSVR01510B1DGC5-571-P1	489	504	571	0.050
450	XSVR01510B1DGC5-621-P1	539	554	621	0.050
500	XSVR01510B1DGC5-671-P1	589	604	671	0.065
550	XSVR01510B1DGC5-721-P1	639	654	721	0.065
600	XSVR01510B1DGC5-771-P1	689	704	771	0.065
700	XSVR01510B1DGC5-871-P1	789	804	871	0.085
800	XSVR01510B1DGC5-971-P1	889	904	971	0.085

XSVR01520-01 Series Specifications (Finish Shaft Ends)

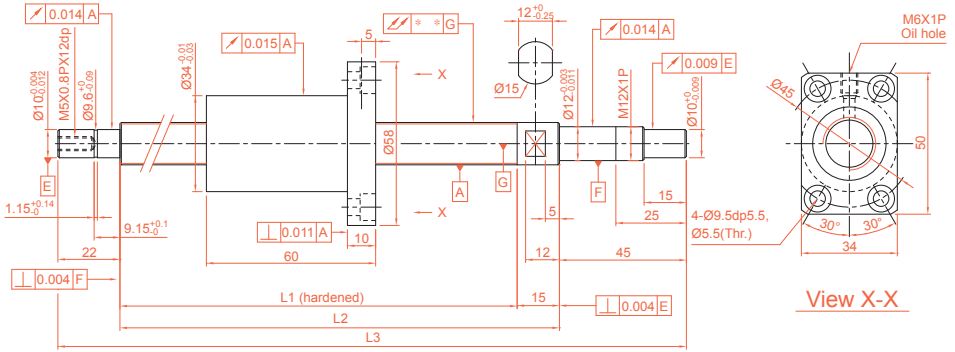

BCD	15.5
Ball Dia (mm)	3.175
Lead (mm)	20
No. of Turns	1.8x1
Lead Angle	22.33°
Threading Direction	R
Spring Force (kg)	0.1~0.3
Preload (kgf)	38
Dynamic Load Rating Ca (kgf)	580
Static Load Rating Coa (kgf)	875
Accuracy Grade	0.018

Unit : mm

Travel Length (mm)	Model No.	Shaft Length (mm)			Slant of Axle Center
		L1	L2	L3	∕
100	XSVR01520A1DGC5-271-P1	189	204	271	0.025
150	XSVR01520A1DGC5-321-P1	239	254	321	0.035
200	XSVR01520A1DGC5-371-P1	289	304	371	0.035
250	XSVR01520A1DGC5-421-P1	339	354	421	0.040
300	XSVR01520A1DGC5-471-P1	389	404	471	0.040
350	XSVR01520A1DGC5-521-P1	439	454	521	0.050
400	XSVR01520A1DGC5-571-P1	489	504	571	0.050
450	XSVR01520A1DGC5-621-P1	539	554	621	0.050
500	XSVR01520A1DGC5-671-P1	589	604	671	0.065
550	XSVR01520A1DGC5-721-P1	639	654	721	0.065
600	XSVR01520A1DGC5-771-P1	689	704	771	0.065
700	XSVR01520A1DGC5-871-P1	789	804	871	0.085
800	XSVR01520A1DGC5-971-P1	889	904	971	0.085

TBI MOTION BALL SCREW

2-3 Rolled Ball Screw

XSVR02010-00 Series Specifications (Finish Shaft Ends)

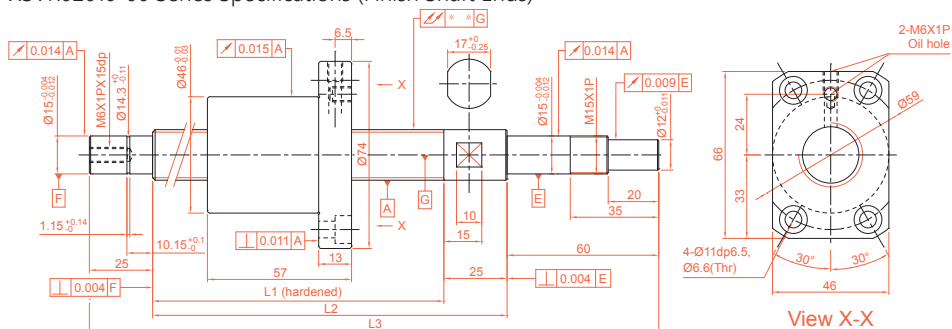

BCD	21.35
Ball Dia (mm)	3.969
Lead (mm)	10
No. of Turns	2.7x1
Lead Angle	8.48°
Threading Direction	R
Spring Force (kg)	0.1~0.3
Preload (kgf)	43
Dynamic Load Rating Ca (kgf)	977
Static Load Rating Coa (kgf)	1732
Accuracy Grade	0.018

Unit : mm

Travel Length (mm)	Model No.	Shaft Length (mm)			Slant of Axle Center
		L1	L2	L3	$\sqrt{\quad}$
200	XSVR02010B1DGC5-399-P1	289	314	399	0.035
300	XSVR02010B1DGC5-499-P1	389	414	499	0.040
400	XSVR02010B1DGC5-599-P1	489	514	599	0.050
500	XSVR02010B1DGC5-699-P1	589	614	699	0.065
600	XSVR02010B1DGC5-799-P1	689	714	799	0.065
700	XSVR02010B1DGC5-899-P1	789	814	899	0.085
800	XSVR02010B1DGC5-999-P1	889	914	999	0.085
900	XSVR02010B1DGC5-1099-P1	989	1014	1099	0.110
1000	XSVR02010B1DGC5-1199-P1	1089	1114	1199	0.110

XSVR02020-00 Series Specifications (Finish Shaft Ends)

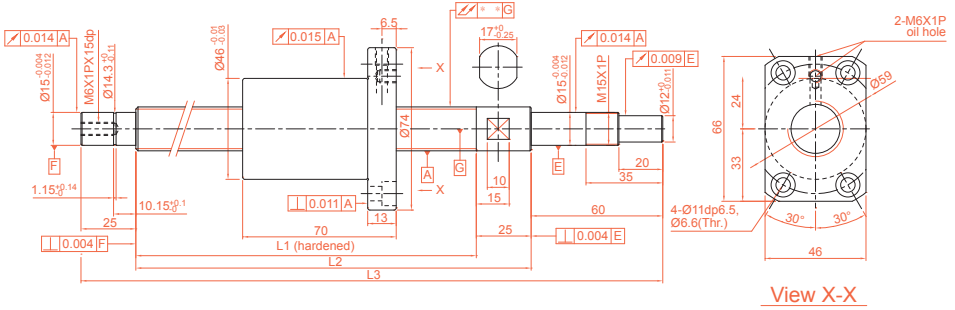

BCD	20.75
Ball Dia (mm)	3.175
Lead (mm)	20
No. of Turns	1.8x1
Lead Angle	17.05°
Threading Direction	R
Spring Force (kg)	0.1~0.3
Preload (kgf)	31
Dynamic Load Rating Ca (kgf)	649
Static Load Rating Coa (kgf)	1134
Accuracy Grade	0.018

Unit : mm

Travel Length (mm)	Model No.	Shaft Length (mm)			Slant of Axle Center
		L1	L2	L3	∕∕
200	XSVR02020A1DGC5-399-P1	289	314	399	0.035
300	XSVR02020A1DGC5-499-P1	389	414	499	0.040
400	XSVR02020A1DGC5-599-P1	489	514	599	0.050
500	XSVR02020A1DGC5-699-P1	589	614	699	0.065
600	XSVR02020A1DGC5-799-P1	689	714	799	0.065
700	XSVR02020A1DGC5-899-P1	789	814	899	0.085
800	XSVR02020A1DGC5-999-P1	889	914	999	0.085
900	XSVR02020A1DGC5-1099-P1	989	1014	1099	0.110
1000	XSVR02020A1DGC5-1199-P1	1089	1114	1199	0.110

TBI MOTION BALL SCREW

2-3 Rolled Ball Screw

■ 2-3-1 Rolled Screws

Rolled screws are made through thread roller. Generally rolled screw has a smoother operation while lowering friction and backlash. Therefore, it gradually replaced the traditional ACME screws and trapezoidal screws. Moreover, rolled screws can eliminate axial play by preloading nut with a cost effective pricing compare to ground screw.

■ 2-3-2 The Features of TBI MOTION Rolled Ball Screw

(1) Lead Accuracy Up to Grade C5

C7 and C10 Screws have been Standardized. C5 on request.

(2) Precision Ground Ball Nut

High Precision Ball Nut are interchangeable between ground and rolled screws.

(3) Available to ship separately

Ball screw and ball nuts can be shipped separated ensure shortest delivery time. The ball nuts are standardized with P0 preloaded, preload value can be adjusted through reballing.

■ 2-3-3 Nominal Model Code of Rolled Ball Screws

Nominal Model Code of Shaft

SC R 025 05 F C7 - 1000 + N3

① ② ③ ④ ⑤ ⑥ ⑦ ⑧

①	④	⑦
Type of Screw Shaft	Lead	Overall Length of Shaft
SC : standard	Unit : mm	Unit : mm
SS : For H, NH type nut		
②	⑤	⑧
Threading Direction	Product Code	Shaft Surface Treatment
R : Right	F : Rolled	□ : Standard
L : Left		B1 : Black Oxidation
		N1 : Hard Chrome Plating
③	⑥	P : Phosphating
Nominal Diameter	Accuracy Grade	N3 : Nickel Plating
Unit : mm	C5, C7, C10	N4 : Raydent
		N5 : Chrome Plating

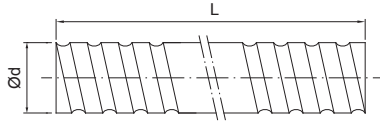

Fig 2.3.1 Screw Shaft Nominal Diameter

Table 2.3.1 Rolled Ball Screw Specifications Ø6~32

Unit : mm

Model No.			Accuracy Grade	Threading Direction R : Right L : Left	Number of Grooves	Standard Code of Shaft	Type of Nut	Overall Length of Shaft
d	l	Da						
6	1	0.8	C10, C7, C5	R	1	SCR00601	K	1000
	1	0.8	C10, C7, C5	R	1	SCR00801	K	
8	2	1.2	C10, C7, C5	R	1	SCR00802	K	1000
	2.5	1.2	C10, C7, C5	R	1	SCR0082.5	K, BSH	
10	2	1.2	C10, C7, C5	R	1	SCR01002	K, BSH	3000
	4	2	C10, C7, C5	R	1	SCR01004	K, BSH	
12	2	1.2	C10, C7, C5	R	1	SCR01202	K	3000
	4	2.5	C10, C7, C5	R	1	SCR01204	U, BSH	
	5	2.5	C10, C7, C5	R	1	SCR01205	K	
	5	2.5	C10, C7, C5	R	1	SSR01205	V, BSH, H, A, J	
	10	2.5	C10, C7, C5	R	1	SCR01210-B	V	
14	2	1.2	C10, C7, C5	R	1	SCR01402	K	3000
	4	2.5	C10, C7, C5	R	1	SCR01404	K, BSH	3000
16	4	2.381	C10, C7, C5	R	1	SCR01604(N)	V, I, U, BSH	3000
	5	3.175	C10, C7, C5	R/L	1	SCR01605	V, NI, NU, BSH	
	10	3.175	C10, C7, C5	R	1	SCR01610	V, NI, NU, BSH	
	16	2.778	C10, C7, C5	R	4	SCR01616	Y, YA	
	32	2.778	C10, C7, C5	R	8	SCR01632	Y, YA	
20	4	2.381	C10, C7, C5	R	1	SCR02004(N)	V, I, U	3000
	5	3.175	C10, C7, C5	R/L	1	SCR02005	V, NI, NU, BSH, H, A, J	
	20	3.175	C10, C7, C5	R	4	SCR02020	V, Y, YA, H, A, J	
	40	3.175	C10, C7, C5	R	8	SCR02040	Y, YA	
25	4	2.381	C10, C7, C5	R	1	SCR02504(N)	I, U	6000
	5	3.175	C10, C7, C5	R/L	1	SCR02505	V, NI, NU, BSH, H, A, J	
	10	4.762	C10, C7, C5	R	1	SCR02510-A	NI, NU, BSH	
	25	3.969	C10, C7, C5	R	4	SCR02525	Y, YA	
	50	3.969	C10, C7, C5	R	8	SCR02550	Y, YA	
32	4	2.381	C10, C7, C5	R	1	SCR03204(N)	V, I, U	6000
	5	3.175	C10, C7, C5	R/L	1	SCR03205	V, NI, NU, M, H, A	
	10	6.35	C10, C7, C5	R/L	1	SCR03210	V, NI, NU	
	32	4.762	C10, C7, C5	R	4	SCR03232	Y, YA	
	64	4.762	C10, C7, C5	R	8	SCR03264	Y, YA	

※ The information is for standard production, if required accuracy grade C5 or other needs, please contact **TBI MOTION**.

※ If the extended type in YA nut is needed, please contact TBI MOTION.

TBI MOTION BALL SCREW

2-3 Rolled Ball Screw

Table 2.3.2 Standard Specifications Ø40~80

Unit : mm

Model No.	Accuracy Grade		Threading Direction R : Right L : Left	Number of Grooves	Standard Code of Shaft	Type of Nut	Overall Length of Shaft	
	d	l						Da
40	5	3.175	C10, C7, C5	R/L	1	SCR04005	V, NI, NU, H, A	6000
	10	6.35	C10, C7, C5	R/L	1	SCR04010	V, NI, NU	
	20	6.35	C10, C7, C5	R	1	SCR04020	V	
	40	6.35	C10, C7, C5	R	4	SCR04040	Y, YA	
	80	6.35	C10, C7, C5	R	8	SCR04080	Y, YA	
50 [•]	5	3.175	C10, C7, C5	R	1	SCR05005	V, H, A	6000
	10	6.35	C10, C7, C5	R/L	1	SCR05010	V, NI, NU	
	20	9.525	C10, C7, C5	R	1	SCR05020	V	
	50	7.938	C10, C7, C5	R	4	SCR05050	Y, YA	
	100	7.938	C10, C7, C5	R	8	SCR050100	Y, YA	
63 [•]	10	6.35	C10, C7, C5	R	1	SCR06310	V, NI, NU	7000
	20	9.525	C10, C7, C5	R	1	SCR06320	V, NU	
80 [•]	10	6.35	C10, C7, C5	R	1	SCR08010	V, NI, NU	7000
	20	9.525	C10, C7, C5	R	1	SCR08020	V, NU	

Table 2.3.3 H/A/J-Type Specifications Ø16~50

Unit : mm

Model No.	Accuracy Grade		Threading Direction R : Right L : Left	Number of Grooves	Type-H Code of Shaft	Type of Nut	Overall Length of Shaft	
	d	l						Da
12	10	2.5	C10, C7, C5	R	2	SSR01210	H, A, J	3000
16	5	2.778	C10, C7, C5	R	1	SSR01605	H, A, J	3000
	10	2.778	C10, C7, C5	R	2	SSR01610	H, A, J	
	16	2.778	C10, C7, C5	R	4	SSR01616	H, A, J	
	20	2.778	C10, C7, C5	R	4	SSR01620	H, A, J	
20	10	3.175	C10, C7, C5	R	2	SSR02010	H, A, J	3000
25	10	3.175	C10, C7, C5	R	2	SSR02510	H, A	6000
	25	3.175	C10, C7, C5	R	4	SSR02525	H, A, V, J	
32	10	3.969	C10, C7, C5	R	1	SSR03210	H, A	6000
	20	3.969	C10, C7, C5	R	2	SSR03220	H, A	
	32	3.969	C10, C7, C5	R	4	SSR03232	H, A	
40	10	6.35	C10, C7, C5	R	1	SSR04010	H, A	6000
	20	6.35	C10, C7, C5	R	2	SSR04020	H, A	
	40	6.35	C10, C7, C5	R	4	SSR04040	H, A	
50 [•]	10	6.35	C10, C7, C5	R	1	SSR05010	H, A	6000
	20	6.35	C10, C7, C5	R	2	SSR05020	H, A	
	50	6.35	C10, C7, C5	R	4	SSR05050	H, A	

※ The information is for standard production, if required accuracy grade C5 or other needs, please contact TBI MOTION.

※ Please contact TBI MOTION if the marked types (•) are required.

※ If the extended type in YA nut is needed, please contact TBI MOTION.

Nominal Model Code of Nut

G SFU R 025 05 T4 D + N3

① ② ③ ④ ⑤ ⑥ ⑦ ⑧

① Product Code		③ Threading Direction		⑥ Number of Turns (Turn-Row)	
S	S : Single nut	R	R : Right	Turn : T : 1	
F	F : With flange	L	L : Left	A : 1.5 (or 1.7/1.8)	
	C : Without flange			B : 2.5/2.8	
U	NI : NI type nut	④ Nominal Diameter		C : 3.5	
	NU : NU type nut	Unit : mm		D : 4.8	
	H : H type nut			E : 5.8	
	A : A type nut			ex : (2.5 × 2 = B2)	
	J : J type nut				
	NH : NH nut (A solution for slide table)	⑤ Lead		⑦ Flange Type	
Y : Y type nut	Unit : mm		N : Not cutting		
YA : YA type nut			S : Single cutting		
V : V type nut			D : Double cutting		
U : U type nut			⑧ Nut Surface Treatment		
M : M type nut			S : Standard		
K : K type nut			B1 : Black Oxidation		
			N1 : Hard Chrome Plating		
			P : Phosphating		
			N3 : Nickel Plating		
			N4 : Raydent		
			N5 : Chrome Plating		

■ 2-3-4 Preload of Rolled Ball Screw

The standard preloading for Rolled Ball Screw is P0. If P1 preloading is required, please contact **TBI MOTION**.

Table 2.3.4 Accuracy grade of rolled ball screw

Unit : μm

Grade		Rolled		
		C5	C7	C10
e ₃₀₀	ISO, DIN	23	52	210
	JIS	18	50	210
	TBI MOTION	23	50	210

TBI MOTION BALL SCREW

2-4 Rolled Ball Screw Series

■ 2-4-1 TBI MOTION Nut of Rolled Ball Screw Type

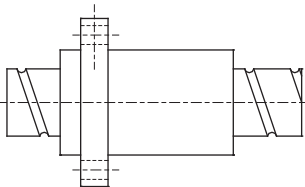
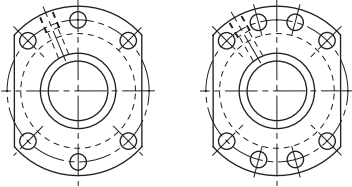
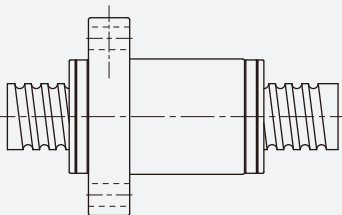
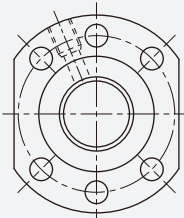
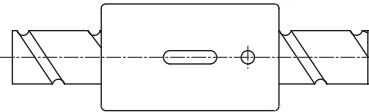
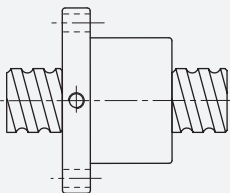
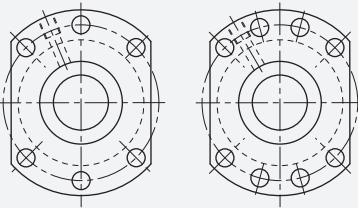
	Nut Type	Flange Type
NH/H/A (A solution for slide table/High Speed/Strong dust-proof type)	<p>SFNH/SFH/SFA (DIN)</p>  <p>C72-73</p>	 <p>$d \leq 32$ $d \geq 40$</p>
J (Low Noise/Strong dust-proof type)	<p>SFJ (DIN)</p>  <p>C74</p>	
CNH (A solution for slide table)	<p>SCNH</p>  <p>C75</p>	No-Flange
NU/N (Strong dust-proof type)	<p>SFNU/ SFU (DIN)</p>  <p>C76</p>	 <p>$d \leq 32$ $d \geq 40$</p>

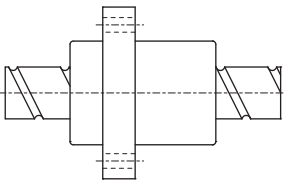
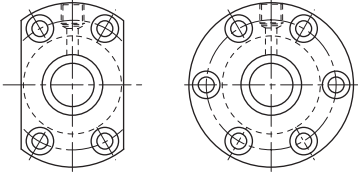
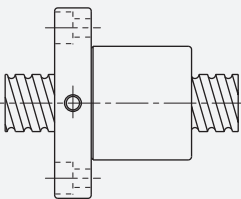
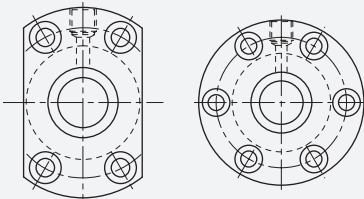
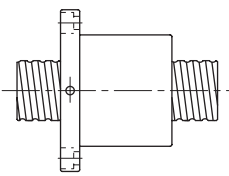
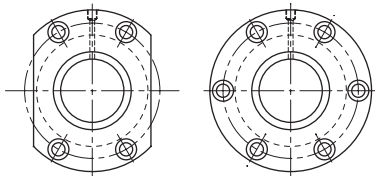
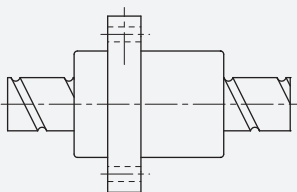
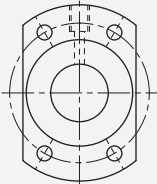

	Nut Type	Flange Type
N/I (Strong dust-proof type)	<p>SFNI/SFI</p>  <p>C77</p>	
M (Design for Milling)	<p>SFM</p>  <p>C77</p>	
> (High Load External Circulation type)	<p>SFV</p>  <p>C78</p>	
Y/YA (High DM-N Rating)	<p>SFY/SFYA</p>  <p>C79, 80</p>	

TBI MOTION BALL SCREW

2-4 Rolled Ball Screw Series

C
Ball Screw

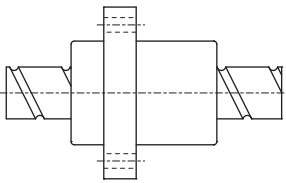
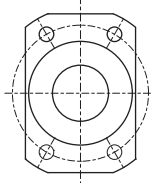
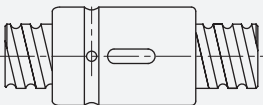
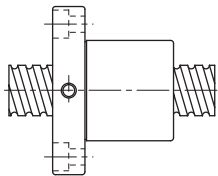
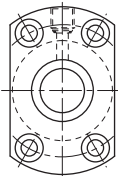
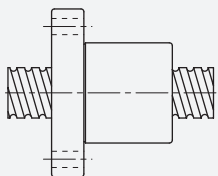
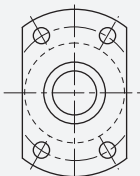
		Nut Type	Flange Type
XSY (Miniature type)		<p>XSY</p>  <p>C81</p>	
		<p>SCNI/SCI</p>  <p>C82</p>	No-Flange
K (Miniature type)		<p>SFK</p>  <p>C83</p>	 <p>(SFK 01004) (SFK 02002) (SFK 02502)</p>
		<p>SFK</p>  <p>C83</p>	

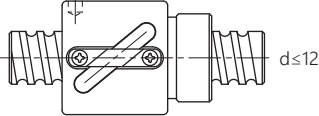
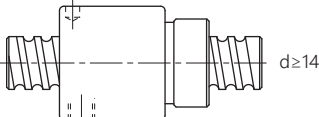
Nut Type		Flange Type
BSH	BSH  $d \leq 12$	No-Flange
	 $d \geq 14$ C84	

※ The information is for specifications, if customized products are needed please contact **TBI MOTION**.

TBI MOTION BALL SCREW

2-4 Rolled Ball Screw Series

SFNH/SFH (DIN 69051 FORM B) Series Specifications

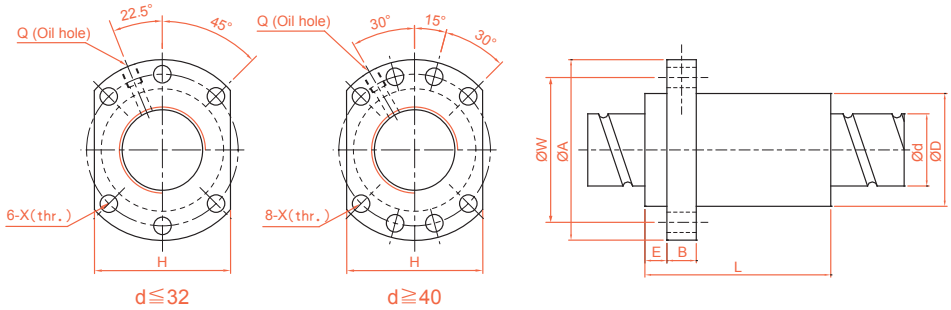

Unit : mm

Model No.	d	l	Da	Dimension										Load Rating		K kgf/μm
				D	A	E	B	L	W	H	X	Q	n	Ca (kgf)	Coa (kgf)	
SFH01205-2.8 *	12	5	2.5	24	40	5	10	30	32	30	4.5		2.8x1	661	1316	19
SFH01210-2.8 *		10	2.5	24	40	5	10	45	32	30	4.5		2.8x1	642	1287	19
SFH01605-3.8 *	15	5	2.778	28	48	5	10	37	38	40	5.5	M6	3.8x1	1112	2507	30
SFH01610-2.8 *		10	2.778	28	48	5	10	45	38	40	5.5	M6	2.8x1	839	1821	23
SFH01616-1.8 *	15	16	2.778	28	48	5	10	45	38	40	5.5	M6	1.8x1	552	1137	14
SFH01616-2.8 *		16	2.778	28	48	5	10	61	38	40	5.5	M6	2.8x1	808	1769	22
SFH01620-1.8 *	15	20	2.778	28	48	7	10	58	38	40	5.5	M6	1.8x1	554	1170	14
SFH02005-3.8 *		5	3.175	36	58	7	10	37	47	44	6.6	M6	3.8x1	1484	3681	37
SFH02010-3.8 *	20	10	3.175	36	58	7	10	55	47	44	6.6	M6	3.8x1	1516	3833	40
SFH02020-1.8 *		20	3.175	36	58	7	10	54	47	44	6.6	M6	1.8x1	764	1758	19
SFH02020-2.8 *	20	20	3.175	36	58	7	10	74	47	44	6.6	M6	2.8x1	1118	2734	29
SFH02505-3.8 *		5	3.175	40	62	7	10	37	51	48	6.6	M6	3.8x1	1650	4658	43
SFH02510-3.8 *	25	10	3.175	40	62	7	12	55	51	48	6.6	M6	3.8x1	1638	4633	45
SFH02525-1.8 *		25	3.175	40	62	7	12	64	51	48	6.6	M6	1.8x1	843	2199	22
SFH02525-2.8 *	25	25	3.175	40	62	7	12	89	51	48	6.6	M6	2.8x1	1232	3421	34
SFH03205-3.8		32	3.175	50	80	9	12	37	65	62	9	M6	3.8x1	1839	6026	51
SFH03210-3.8	31	10	3.969	50	80	9	12	57	65	62	9	M6	3.8x1	2460	7255	55
SFH03220-2.8		20	3.969	50	80	9	12	76	65	62	9	M6	2.8x1	1907	5482	43
SFH03232-1.8	31	32	3.969	50	80	9	12	80	65	62	9	M6	1.8x1	1257	3426	27
SFH03232-2.8		32	3.969	50	80	9	12	112	65	62	9	M6	2.8x1	1838	5329	42
SFH04005-3.8	40	5	3.175	63	93	9	15	42	78	70	9	M8	3.8x1	2018	7589	60
SFH04010-3.8		10	6.35	63	93	9	14	60	78	70	9	M8	3.8x1	5035	13943	67
SFH04020-2.8	38	20	6.35	63	93	9	14	80	78	70	9	M8	2.8x1	3959	10715	54
SFH04040-1.8		40	6.35	63	93	9	14	98	78	70	9	M8	1.8x1	2585	6648	34
SFH04040-2.8	38	40	6.35	63	93	9	14	138	78	70	9	M8	2.8x1	3780	10341	52
SFH05005-3.8 •		50	3.175	75	110	10.5	15	42	93	85	11	M8	3.8x1	2207	9542	68
SFH05010-3.8 •	48	10	6.35	75	110	10.5	18	60	93	85	11	M8	3.8x1	5638	17852	79
SFH05020-3.8 •		20	6.35	75	110	10.5	18	100	93	85	11	M8	3.8x1	5749	18485	87
SFH05050-1.8 •	48	50	6.35	75	110	10.5	18	120	93	85	11	M8	1.8x1	2946	8749	42
SFH05050-2.8 •		50	6.35	75	110	10.5	18	170	93	85	11	M8	2.8x1	4308	13610	65

※ ★ Actuator type available.

※ Please contact TBI MOTION if the marked types (•) are required.

SFA (DIN 69051 FORM B) Series Specifications

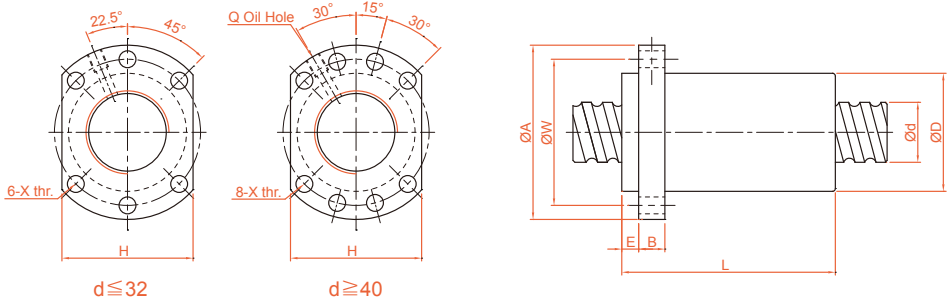

Unit : mm

Model No.	d	l	Da	Dimension										Load Rating		K kgf/ μm
				D	A	E	B	L	W	H	X	Q	n	Ca (kgf)	Coa (kgf)	
SFA1205-2.8*	12	5	2.5	24	40	5	10	30	32	30	4.5	-	2.8×1	661	1316	19
SFA1210-2.8*		10	2.5	24	40	5	10	42	32	30	4.5	-	2.8×1	642	1287	19
SFA1605-3.8*	15	5	2.778	28	48	5	10	31	38	40	5.5	M6	3.8×1	1112	2507	30
SFA1610-2.8*		10	2.778	28	48	5	10	42	38	40	5.5	M6	2.8×1	839	1821	23
SFA1616-1.8*		16	2.778	28	48	5	10	43	38	40	5.5	M6	1.8×1	552	1137	14
SFA1616-2.8*		16	2.778	28	48	5	10	59	38	40	5.5	M6	2.8×1	808	1769	22
SFA1620-1.8*	20	2.778	28	48	5	10	50	38	40	5.5	M6	1.8×1	554	1170	14	
SFA2005-3.8*	20	5	3.175	36	58	7	10	33	47	44	6.6	M6	3.8×1	1484	3681	37
SFA2010-3.8*		10	3.175	36	58	7	10	52	47	44	6.6	M6	3.8×1	1516	3833	40
SFA2020-1.8*		20	3.175	36	58	7	10	52	47	44	6.6	M6	1.8×1	764	1758	19
SFA2020-2.8*		20	3.175	36	58	7	10	72	47	44	6.6	M6	2.8×1	1118	2734	29
SFA2505-3.8*	25	5	3.175	40	62	7	10	33	51	48	6.6	M6	3.8×1	1650	4658	43
SFA2510-3.8*		10	3.175	40	62	7	12	52	51	48	6.6	M6	3.8×1	1638	4633	45
SFA2525-1.8*		25	3.175	40	62	7	12	60	51	48	6.6	M6	1.8×1	843	2199	22
SFA2525-2.8*		25	3.175	40	62	7	12	85	51	48	6.6	M6	2.8×1	1232	3421	34
SFA3205-3.8	32	5	3.175	50	80	9	12	35	65	62	9	M6	3.8×1	1839	6026	51
SFA3210-3.8	31	10	3.969	50	80	9	12	53	65	62	9	M6	3.8×1	2460	7255	55
SFA3220-2.8		20	3.969	50	80	9	12	72	65	62	9	M6	2.8×1	1907	5482	43
SFA3232-1.8		32	3.969	50	80	9	12	78	65	62	9	M6	1.8×1	1257	3426	27
SFA3232-2.8		32	3.969	50	80	9	12	110	65	62	9	M6	2.8×1	1838	5329	42
SFA4005-3.8	40	5	3.175	63	93	9	14	39	78	70	9	M8	3.8×1	2018	7589	60
SFA4010-3.8	38	10	6.35	63	93	9	14	57	78	70	9	M8	3.8×1	5035	13943	67
SFA4020-2.8		20	6.35	63	93	9	14	78	78	70	9	M8	2.8×1	3959	10715	54
SFA4040-1.8		40	6.35	63	93	9	14	96	78	70	9	M8	1.8×1	2585	6648	34
SFA4040-2.8		40	6.35	63	93	9	14	136	78	70	9	M8	2.8×1	3780	10341	52
SFA5005-3.8*	50	5	3.175	75	110	10.5	15	42	93	85	11	M8	3.8×1	2207	9542	68
SFA5010-3.8*	48	10	6.35	75	110	10.5	18	57	93	85	11	M8	3.8×1	5638	17852	79
SFA5020-3.8*		20	6.35	75	110	10.5	18	98	93	85	11	M8	3.8×1	5749	18485	87
SFA5050-1.8*		50	6.35	75	110	10.5	18	117	93	85	11	M8	1.8×1	2946	8749	42
SFA5050-2.8*		50	6.35	75	110	10.5	18	167	93	85	11	M8	2.8×1	4308	13610	65

※ ★ Actuator type available.

※ Please contact TBI MOTION if the marked types (●) are required.

TBI MOTION BALL SCREW

2-4 Rolled Ball Screw Series

SFJ (DIN 69051 FORM B) Series Specifications

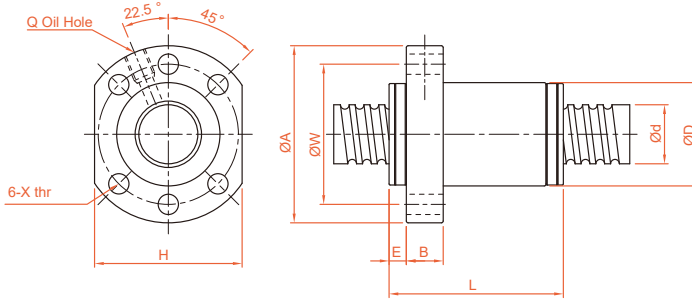

Unit : mm

Model No.	d	l	Da	Dimension										Load Rating		K kgf/ µm
				D	A	E	B	L	W	H	X	Q	n	Ca (kgf)	Coa (kgf)	
SFJ01205-2.8	12	5	2.5	24	40	3.5	10	31	32	30	4.5	-	2.8x1	418	753	12
SFJ01210-2.8		10		24	40	4.7	10	48.5	32	30	4.5	-	2.8x1	405	752	12
SFJ01605-3.8	15	5	2.778	28	48	4	10	38	38	40	5.5	M6x1	3.8x1	706	1472	20
SFJ01610-2.8		10		28	48	4.7	10	48	38	40	5.5	M6x1	2.8x1	532	1082	15
SFJ01616-1.8		16		28	48	4	10	45.5	38	40	5.5	M6x1	1.8x1	364	693	10
SFJ01620-1.8		20		28	48	4.7	10	56.5	38	40	5.5	M6x1	1.8x1	351	696	10
SFJ02005-3.8	20	5	3.175	36	58	6	10	40	47	44	6.6	M6x1	3.8x1	975	2293	25
SFJ02010-3.8		10		36	58	6	10	57	47	44	6.6	M6x1	3.8x1	996	2302	27
SFJ02020-1.8		20		36	58	6	10	57	47	44	6.6	M6x1	1.8x1	503	1056	12
SFJ02505-3.8	25	5	3.175	40	62	6	10	40	51	48	6.6	M6x1	3.8x1	1084	2879	30
SFJ02510-3.8		10		40	62	6	12	62	51	48	6.6	M6x1	3.8x1	1076	2863	31
SFJ02525-1.8		25		40	62	6	12	70	51	48	6.6	M6x1	1.8x1	554	1351	15

SCNH Series Specifications

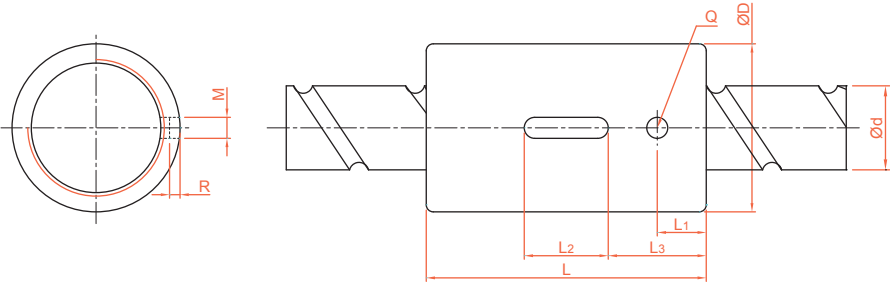

Unit : mm

Model No.	d	l	Da	Dimension										Load Rating		K kgf/μm
				D	L	L1	L2	L3	M	R	Q	n	Ca (kgf)	Coa (kgf)		
SCNH01205-4.8	12	5	2.5	24	40	7	12	14	3	1.5	3	4.8x1	1051	2255	34	
SCNH01210-2.8		10	2.5	24	45	8	15	15	3	1.5	3	2.8x1	642	1287	19	
XCNH01210-1.8		10	2.5	24	40	10.5	12	14	3	1.5	3	1.8x1	439	827	33	
SCNH01605-5.8	15	5	2.778	28	45	7	20	12.5	5	3	3	5.8x1	1599	3827	49	
SCNH01610-2.8		10	2.778	28	45	7	20	12.5	5	3	3	2.8x1	839	1821	23	
SCNH01616-1.8		16	2.778	28	45	7	20	12.5	5	3	3	1.8x1	552	1137	18	
SCNH01620-1.8		20	2.778	28	58	10	20	19	5	3	3	1.8x1	554	1170	14	
SCNH02005-5.8	20	5	3.175	36	47	8	20	13.5	5	3	3	5.8x1	2134	5619	60	
SCNH02010-3.8		10	3.175	36	55	8	20	17.5	5	3	3	3.8x1	1516	3833	40	
SCNH02020-1.8		20	3.175	36	55	8	20	17.5	5	3	3	1.8x1	764	1758	19	

TBI MOTION BALL SCREW

2-4 Rolled Ball Screw Series

SFNU/SFU (DIN 69051 FORM B) Series Specifications

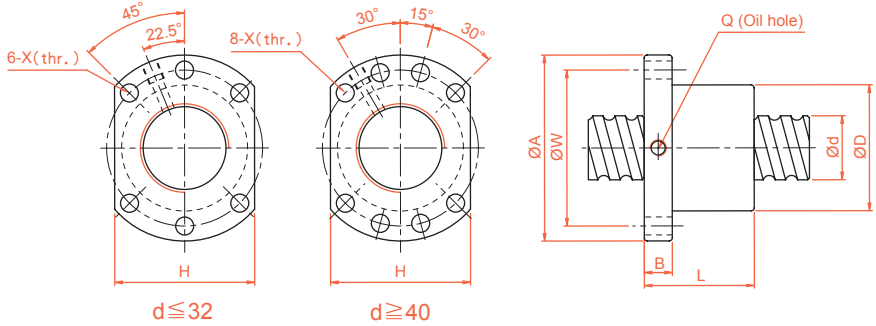

Unit : mm

Model No.	d	l	Da	Dimension									Load Rating		K kgf/ μm
				D	A	B	L	W	H	X	Q	n	Ca (kgf)	Coa (kgf)	
SFNU01605-4 [★]	16	5	3.175	28	48	10	45	38	40	5.5	M6	1x4	1380	3052	32
SFNU01610-3		10	3.175	28	48	10	57	38	40	5.5	M6	1x3	1103	2401	26
SFNU02005-4 [★]	20	5	3.175	36	58	10	51	47	44	6.6	M6	1x4	1551	3875	39
SFNU02505-4 [★]		5	3.175	40	62	10	51	51	48	6.6	M6	1x4	1724	4904	45
SFNU02510-4	25	10	4.762	40	62	12	80	51	48	6.6	M6	1x4	2954	7295	50
SFNU03205-4 [★]		5	3.175	50	80	12	52	65	62	9	M6	1x4	1922	6343	54
SFNU03210-4 [★]	32	10	6.35	50	80	12	85	65	62	9	M6	1x4	4805	12208	61
SFNU04005-4 [★]		5	3.175	63	93	14	55	78	70	9	M8	1x4	2110	7988	63
SFNU04010-4 [★]	40	10	6.35	63	93	14	88	78	70	9	M8	1x4	5399	15500	73
SFNU05010-4 ^{★●}		50	10	6.35	75	110	16	88	93	85	11	M8	1x4	6004	19614
SFNU06310-4 [●]	63	10	6.35	90	125	18	93	108	95	11	M8	1x4	6719	25358	99
SFNU06320-4 [●]		20	9.525	95	135	20	149	115	100	13.5	M8	1x4	11444	36653	112
SFNU08010-4 [●]	80	10	6.35	105	145	20	93	125	110	13.5	M8	1x4	7346	31953	109
SFNU08020-4 [●]		20	9.525	125	165	25	154	145	130	13.5	M8	1x4	12911	47747	138
SFU01204-4	12	4	2.5	24	40	10	40	32	30	4.5		1x4	902	1884	26
SFU01604-4		16	4	2.381	28	48	10	40	38	40	5.5	M6	1x4	973	2406
SFU02004-4	20	4	2.381	36	58	10	42	47	44	6.6	M6	1x4	1066	2987	38
SFU02504-4		4	2.381	40	62	10	42	51	48	6.6	M6	1x4	1180	3795	43
SFU03204-4	32	4	2.381	50	80	12	44	65	62	9	M6	1x4	1296	4838	51
SFU10020-4 [●]		100	20	9.525	150	202	30	180	170	155	17.5	M8	1x4	14303	60698

※ ★ Left helix available ※ Please contact TBI MOTION if the marked types (●) are required.

※ Standard ball nut SFU01204-4 is assembled without wiper.

SFNI/SFI Series Specifications

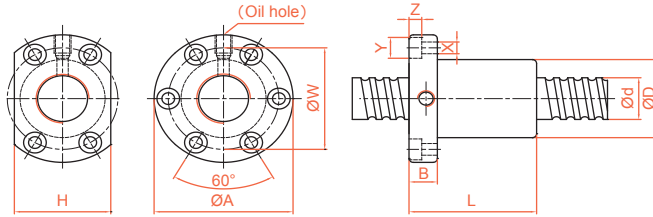

Unit : mm

Model No.	d	l	Da	Dimension											Load Rating		K kgf/μm
				D	A	B	L	W	H	X	Y	Z	Q	n	Ca (kgf)	Coa (kgf)	
SFNI01605-4*	16	5	3.175	30	49	10	45	39	34	4.5	8	4.5	M6	1x4	1380	3052	33
SFNI01610-3		10	3.175	34	58	10	57	45	34	5.5	9.5	5.5	M6	1x3	1103	2401	27
SFNI02005-4*	20	5	3.175	34	57	11	51	45	40	5.5	9.5	5.5	M6	1x4	1551	3875	39
SFNI02505-4*	25	5	3.175	40	63	11	51	51	46	5.5	9.5	5.5	M8	1x4	1724	4904	45
SFNI02510-4		10	4.762	46	72	12	80	58	52	6.5	11	6.5	M6	1x4	2954	7295	51
SFNI03205-4*	32	5	3.175	46	72	12	52	58	52	6.5	11	6.5	M8	1x4	1922	6343	52
SFNI03210-4*		10	6.35	54	88	15	85	70	62	9	14	8.5	M8	1x4	4805	12208	62
SFNI04005-4*	40	5	3.175	56	90	15	55	72	64	9	14	8.5	M8	1x4	2110	7988	59
SFNI04010-4*		10	6.35	62	104	18	88	82	70	11	17.5	11	M8	1x4	5399	15500	72
SFNI05010-4*●	50	10	6.35	72	114	18	88	92	82	11	17.5	11	M8	1x4	6004	19614	83
SFNI06310-4●	63	10	6.35	85	131	22	93	107	95	14	20	13	M8	1x4	6719	25358	95
SFNI08010-4●	80	10	6.35	105	150	22	93	127	115	14	20	13	M8	1x4	7346	31953	109
SFI01604-4	16	4	2.381	30	49	10	45	39	34	4.5	8	4.5	M6	1x4	973	2406	32
SFI02004-4	20	4	2.381	34	57	11	46	45	40	5.5	9.5	5.5	M6	1x4	1066	2987	37
SFI0205T-4		5.08	3.175	34	57	11	51	45	40	5.5	9.5	5.5	M6	1x4	1550	3875	39
SFI02504-4	25	4	2.381	40	63	11	46	51	46	5.5	9.5	5.5	M6	1x4	1180	3795	43
SFI0255T-4		5.08	3.175	40	63	11	51	51	46	5.5	9.5	5.5	M8	1x4	1724	4903	45
SFI03204-4	32	4	2.381	46	72	12	47	58	52	6.5	11	6.5	M6	1x4	1296	4838	49

※ Please contact TBI MOTION if the marked types (●) are required.

SFM Series Specifications (Design for Milling)

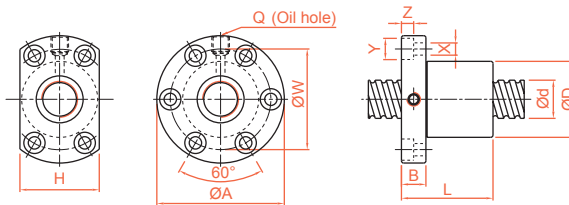

Unit : mm

Model No.	d	l	Da	Dimension											Load Rating		K kgf/μm
				D	A	B	L	W	H	X	Y	Z	Q	n	Ca (kgf)	Coa (kgf)	
SFM03205-4*	32	5	3.175	48	74	12	52	60	60	6.5	11	6.5	M8	1x4	1922	6343	53
SFM0325T-4*		5.08	3.175	48	74	12	53	60	60	6.5	11	6.5	M8	1x4	1922	6343	53

※ ☆ Left helix available

TBI MOTION BALL SCREW

2-4 Rolled Ball Screw Series

SFV Series Specifications

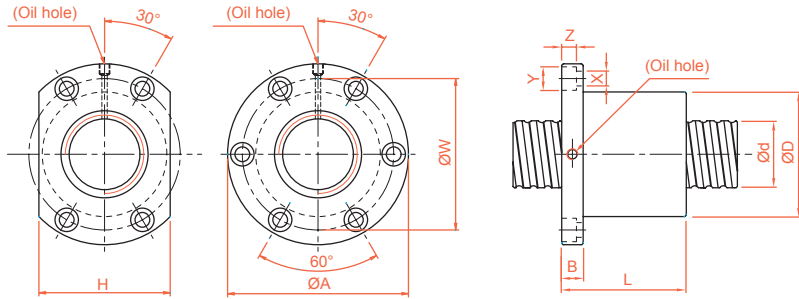

Unit : mm

Model No.	d	l	Da	Dimension												Load Rating		K kgf/μm
				D	A	B	L	W	H	X	Y	Z	Q	n	Ca (kgf)	Coa (kgf)		
SFV01205-2.8	12	5	2.5	30	50	10	42	40	32	4.5	8	4.5	M6	2.8x1	661	1316	19	
SFV01210-2.7		10	2.5	30	50	10	53	40	32	4.5	8	4.5	M6	2.7x1	623	1241	18	
SFV01604-3.8	16	4	2.381	34	57	11	45	45	34	5.5	9.5	5.5	M6	3.8x1	931	2285	31	
SFV01605-4.8		5	3.175	40	63	11	58	51	42	5.5	9.5	5.5	M6	4.8x1	1614	3662	40	
SFV01610-2.7	20	10	3.175	40	63	11	56	51	42	5.5	9.5	5.5	M6	2.7x1	1008	2161	24	
SFV02004-4.8		4	2.381	40	60	10	50	50	40	4.5	8	4	M6	4.8x1	1247	3584	45	
SFV02005-4.8	20	5	3.175	44	67	11	57	55	52	5.5	9.5	5.5	M6	4.8x1	1814	4650	47	
SFV02020-1.8		20	3.175	46	74	13	70	59	46	6.6	11	6.5	M6	1.8x1	764	1758	19	
SFV02505-4.8	25	5	3.175	50	73	11	55	61	52	5.5	9.5	5.5	M8	4.8x1	2017	5884	56	
SFV02525-1.8		25	3.175	50	73	13	83	61	52	5.5	9.5	5.5	M8	1.8x1	843	2199	22	
SFV03204-4.8	32	4	2.381	54	81	12	50	67	64	6.6	11	6.5	M6	4.8x1	1517	5806	62	
SFV03205-4.8		5	3.175	58	85	12	56	71	64	6.6	11	6.5	M8	4.8x1	2249	7612	66	
SFV03210-4.8	40	10	6.35	74	108	15	96	90	82	9	14	9	M8	4.8x1	5620	14649	76	
SFV04005-4.8		5	3.175	67	101	15	59	83	72	9	14	8.5	M8	4.8x1	2468	9586	76	
SFV04010-4.8	40	10	6.35	82	124	18	100	102	94	11	17.5	11	M8	4.8x1	6316	18600	90	
SFV04020-2.7		20	6.35	82	124	18	100	102	90	11	17.5	11	M8	2.7x1	3935	10893	56	
SFV05005-4.8 [•]	50	5	3.175	80	114	15	60	96	82	9	14	8.5	M8	4.8x1	2698	12053	87	
SFV05010-4.8 [•]		10	6.35	93	135	16	93	113	98	11	17.5	11	M8	4.8x1	7023	23537	106	
SFV05020-2.7 [•]		20	9.525	105	152	28	121	128	110	14	20	13	M8	2.7x1	7336	19700	68	
SFV06310-4.8 [•]	63	10	6.35	108	154	22	105	130	110	14	20	13	M8	4.8x1	7860	30430	126	
SFV06320-2.7 [•]		20	9.525	122	180	28	120	150	130	18	26	17.5	M8	2.7x1	8162	24741	80	
SFV08010-4.8 [•]	80	10	6.35	130	176	22	105	152	132	14	20	13	M8	4.8x1	8593	38344	145	
SFV08020-4.8 [•]		20	9.525	143	204	28	180	172	148	18	26	18	M8	4.8x1	15103	57296	168	
SFV08020-7.6 [•]		20	9.525	143	204	28	240	172	148	18	26	18	M8	3.8x2	22423	90719	260	

※ Please contact TBI MOTION if the marked types (•) are required.

SFY Series Specifications

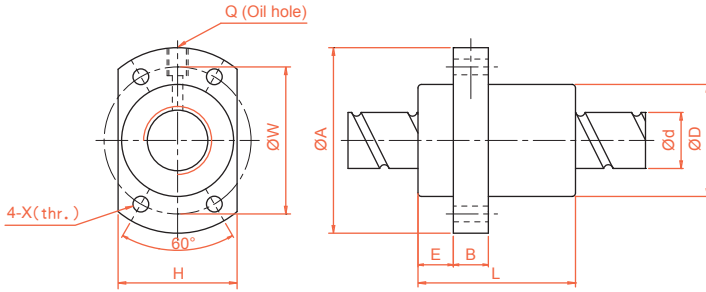

Unit : mm

Large Lead Model No.	d	l	Da	Dimension										Load Rating		K kgf/μm
				D	A	E	B	L	W	H	X	Q	n	Ca (kgf)	Coa (kgf)	
SFY01616-3.6	16	16	2.778	32	53	10.1	10	45	42	34	4.5	M6	1.8x2	1073	2551	31
SFY02020-3.6	20	20	3.175	39	62	13	10	52	50	41	5.5	M6	1.8x2	1387	3515	37
SFY02525-3.6	25	25	3.969	47	74	15	12	64	60	49	6.6	M6	1.8x2	2074	5494	45
SFY03232-3.6	32	32	4.762	58	92	17	12	78	74	60	9	M6	1.8x2	3021	8690	58
SFY04040-3.6	40	40	6.35	73	114	19.5	15	99	93	75	11	M6	1.8x2	4831	14062	70
SFY05050-3.6*	50	50	7.938	90	135	21.5	20	117	112	92	14	M6	1.8x2	7220	21974	86
Twin Lead Model No.	d	l	Da	Dimension										Ca (kgf)	Coa (kgf)	K kgf/μm
				D	A	E	B	L	W	H	X	Q	n			
SFY01632-1.6	16	32	2.778	32	53	10.1	10	42.5	42	34	4.5	M6	0.8x2	493	1116	11
SFY02040-1.6	20	40	3.175	39	62	13	10	48	50	41	5.5	M6	0.8x2	653	1597	15
SFY02550-1.6	25	50	3.969	47	74	15	12	58	60	49	6.6	M6	0.8x2	976	2495	19
SFY03264-1.6	32	64	4.762	58	92	17	12	71	74	60	9	M6	0.8x2	1374	3571	22
SFY04080-1.6	40	80	6.35	73	114	19.5	15	90	93	75	11	M6	0.8x2	2273	6387	29
SFY050100-1.6*	50	100	7.938	90	135	21.5	20	111	112	92	14	M6	0.8x2	3398	9980	35

※Please contact TBI MOTION if the marked types (●) are required.

TBI MOTION BALL SCREW

2-4 Rolled Ball Screw Series

SFYA Series Specifications

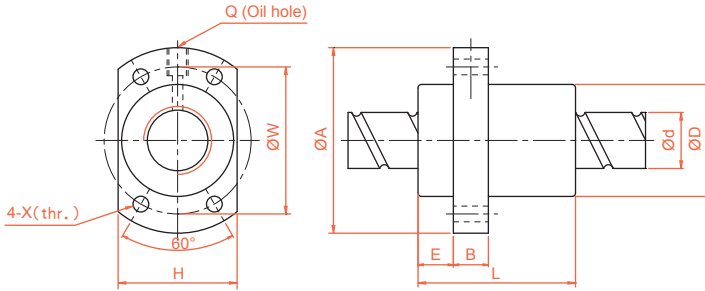

Unit : mm

Large Lead Model No.	d	l	Da	Dimension										Load Rating		K kgf/μm
				D	A	E	B	L	W	H	X	Q	n	Ca (kgf)	Coa (kgf)	
SFYA01616-3.6	16	16	2.778	32	53	10.1	10	45	42	34	4.5	M6	1.8*2	1073	2551	31
SFYA02020-3.6	20	20	3.175	39	62	13	10	52	50	41	5.5	M6	1.8*2	1387	3515	37
SFYA02525-3.6	25	25	3.969	47	74	15	12	64	60	49	6.6	M6	1.8*2	2074	5494	45
SFYA03232-3.6	32	32	4.762	58	92	17	12	78	74	60	9	M6	1.8*2	3021	8690	58
SFYA04040-3.6	40	40	6.35	73	114	19.5	15	99	93	75	11	M6	1.8*2	4831	14062	70
SFYA05050-3.6	50	50	7.938	90	135	21.5	20	117	112	92	14	M6	1.8*2	7220	21974	86
Twin Lead Model No.	d	l	Da	Dimension										Ca (kgf)	Coa (kgf)	K kgf/μm
SFYA01632-1.6	16	32	2.778	32	53	10.1	10	42.5	42	34	4.5	M6	0.8*2	493	1116	11
SFYA02040-1.6	20	40	3.175	39	62	13	10	48	50	41	5.5	M6	0.8*2	653	1597	15
SFYA02550-1.6	25	50	3.969	47	74	15	12	58	60	49	6.6	M6	0.8*2	976	2495	19
SFYA03264-1.6	32	64	4.762	58	92	17	12	71	74	60	9	M6	0.8*2	1374	3571	22
SFYA04080-1.6	40	80	6.35	73	114	19.5	15	90	93	75	11	M6	0.8*2	2273	6387	29
SFYA050100-1.6	50	100	7.938	90	135	21.5	20	111	112	92	14	M6	0.8*2	3398	9980	35

※Please contact TBI MOTION if the marked types (●) are required.

XSX Series Specifications

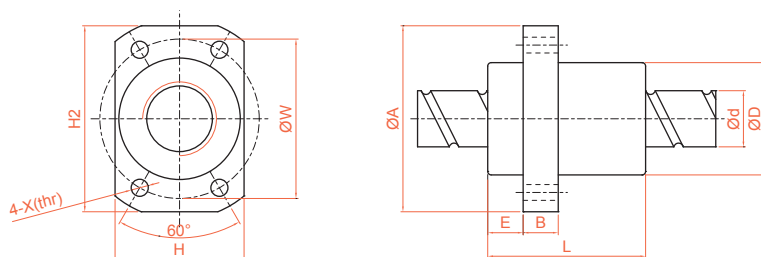

Unit : mm

Model No.	d	l	Da	Dimension										Load Rating		K kgf/μm
				D	A	E	B	L	W	H	H2	X	n	Ca (kgf)	Coa (kgf)	
XSXR01220A2D-00	12	20	2.5	24	41	3.8	5	50	32	24	36	4.5	1.8x2	777	1718	13

XCYA Series Specifications

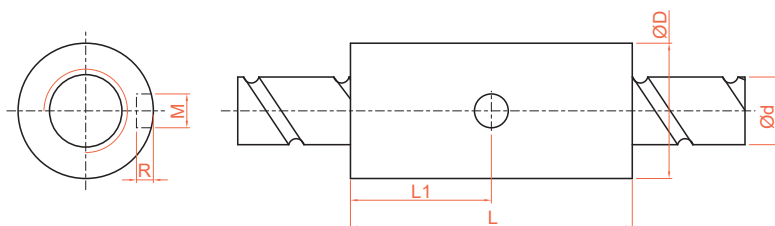

單位 : mm

Model No.	d	l	Da	Dimension							Load Rating		K kgf/μm
				D	A	E	B	L	W	Ca (kgf)	Coa (kgf)		
XCYAR01220A2-00	12	20	2.5	24	50	25	6	3	1.8*2	777	1718	13	

TBI MOTION BALL SCREW

2-4 Rolled Ball Screw Series

SCNI/SCI Series Specifications

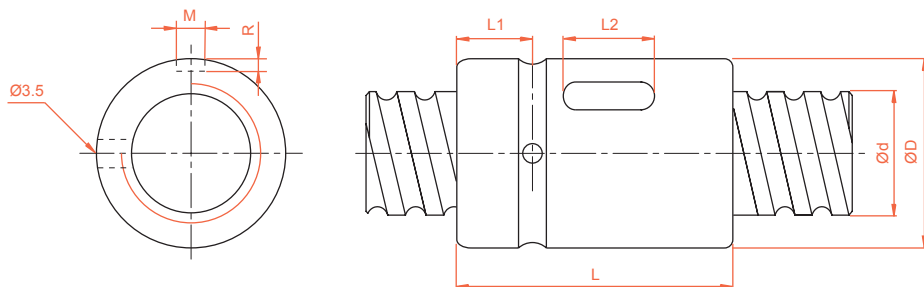

Unit : mm

Model No.	d	l	Da	Dimension							Load Rating		K kgf/μm
				D	L	L1	L2	M	R	n	Ca (kgf)	Coa (kgf)	
SCNI 01605-4	16	5	3.175	30	45	9	20	5	3	1x4	1380	3052	33
SCNI 02005-4	20	5	3.175	34	45	9	20	5	3	1x4	1551	3875	39
SCNI 02505-4	25	5	3.175	40	45	9	20	5	3	1x4	1724	4904	45
SCNI 02510-4		10	4.762	46	85	13	30	5	3	1x4	2954	7295	51
SCNI 03205-4	32	5	3.175	46	45	9	20	5	3	1x4	1922	6343	52
SCNI 03210-4		10	6.35	54	85	13	30	5	3	1x4	4805	12208	62
SCNI 04005-4	40	5	3.175	56	45	9	20	5	3	1x4	2110	7988	59
SCNI 04010-4		10	6.35	62	85	13	30	5	3	1x4	5399	15500	72
SCNI 05010-4*	50	10	6.35	72	85	13	30	5	3	1x4	6004	19614	83
SCNI 06310-4*	63	10	6.35	85	85	13	30	6	3.5	1x4	6719	25358	95
SCNI 08010-4*	80	10	6.35	105	85	13	30	8	4.5	1x4	7346	31953	109
SCI 01604-4	16	4	2.381	30	40	9	15	3	1.5	1x4	973	2406	32
SCI 02004-4	20	4	2.381	34	40	9	15	3	1.5	1x4	1066	2987	37
SCI 02504-4	25	4	2.381	40	40	9	15	3	1.5	1x4	1180	3795	43
SCI 03204-4	32	4	2.381	46	40	9	15	3	1.5	1x4	1296	4838	49

*Please contact TBI MOTION if the marked types (●) are required.

SFK Series Specifications

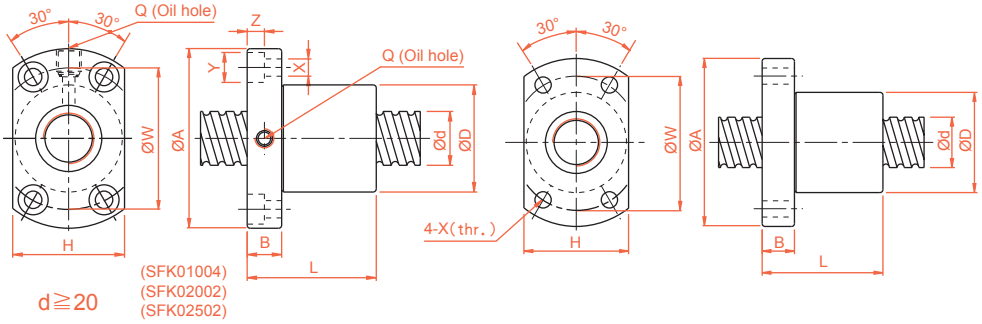

Unit : mm

Model No.	d	l	Da	Dimension										Ca (kgf)	Coa (kgf)	K (kgf/ μ m)	
				D	A	B	L	W	H	X	Y	Z	Q				n
SFK00601	6	1	0.8	12	24	3.5	15	18	16	3.4	-	-	-	1x3	111	224	9
SFK00801	8	1	0.8	14	27	4	16	21	18	3.4	-	-	-	1x4	161	403	14
SFK00802		2	1.2	14	27	4	18	21	18	3.4	-	-	-	1x3	222	458	13
SFK0082.5		2.5	1.2	16	29	4	26	23	20	3.4	-	-	-	1x3	221	457	13
SFK01002		2	1.2	18	35	5	28	27	22	4.5	-	-	-	1x3	243	569	15
SFK01004	10	4	2	20	37	6	34	29	28	4.5	-	-	-	1x3	468	905	17
SFK01202		2	1.2	20	37	5	28	29	24	4.5	-	-	-	1x4	334	906	22
SFK01205		5	2.5	22	37	8	39	29	24	4.5	-	-	-	1x3	702	1409	17
SFK01402		2	1.2	21	40	6	23	31	26	5.5	-	-	-	1x4	354	1053	24
SFK01404	14	4	2.5	25	42	10	40	35	29	4.5	-	-	-	1x4	957	2155	16
XSFK01004		10	4	2	26	46	10	34	36	28	4.5	8	4.5	M6x1	1x3	468	905
XSFK01404	14	4	2.5	26	46	10	45	36	28	4.5	8	4.5	M6x1	1x4	957	2145	16

※ Type K standard ball Nut is available for with or without wiper, please contact TBI sales representatives.

Unit : mm

Model No.	d	l	Da	Dimension										Ca (kgf)	Coa (kgf)	K (kgf/ μ m)	
				D	A	B	L	W	H	X	Y	Z	Q				n
XSUR01204T3D-02	12	4	2.5	24	40	6	28	32	25	3.5	-	-	-	1x3	704	1413	-

※ Standard ball nut XSUR01204T3D-02 is assembled without wiper.

TBI MOTION BALL SCREW

2-4 Rolled Ball Screw Series

BSH Series Specifications

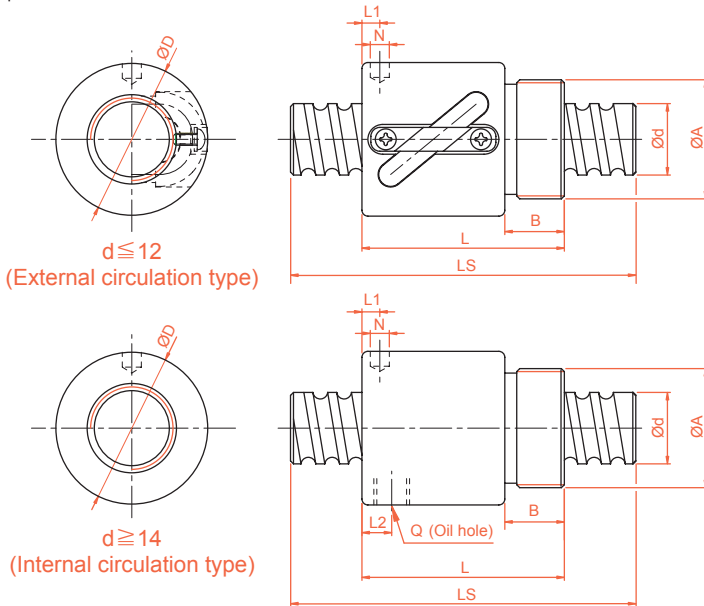

Unit : mm

Model No.	d	l	Da	Dimension									Ca (kgf)	Coa (kgf)	K kgf/ μ m
				D	A	B	L	L1	N	L2	Q	n			
BSHR0082.5-2.5	8	2.5	1.2	17.5	M15x1P	7.5	23.5	10	3	-	-	2.5x1	189	381	11
BSHR01002-3.5	10	2	1.2	19.5	M17x1P	7.5	22	3	3.2	-	-	3.5x1	277	664	17
BSHR01004-2.5		4	2	25	M20x1P	10	34	3	3	-	-	2.5x1	400	754	14
BSHR01204-3.5	12	4	2.5	25.5	M20x1P	10	34	13	3	-	-	3.5x1	804	1649	23
BSHR01205-3.5		5	2.5	25.5	M20x1P	10	39	16.25	3	-	-	3.5x1	801	1644	24
BSHR01404-3	14	4	2.5	32.1	M25x1.5P	10	35	11	3	-	-	1x3	748	1609	26
BSHR01604-3	16	4	2.381	29	M22x1.5P	8	32	4	3.2	-	-	1x3	759	1804	24
BSHR01605-3		5	3.175	32.5	M26x1.5P	12	42	19.25	3	-	-	1x3	1077	2289	25
BSHR01610-2		10	3.175	32	M26x1.5P	12	50	3	4	3	M4	1x2	779	1601	14
BSHR02005-3	20	5	3.175	38	M35x1.5P	15	45	20.3	3	-	-	1x3	1211	2906	30
BSHR02505-4	25	5	3.175	43	M40x1.5P	19	69	32.11	3	8	M6	1x4	1724	4904	37
BSHR02510-4		10	4.762	43	M40x1.5P	19	84	8	6	8	M6	1x4	2954	7295	41

※ Standard ballnut from $\phi 8$ ~ $\phi 16$ is assembled without wiper

2-5 Ball Screw Weight List

Model No.	Weight	
	Ball Nut(kg)	Screw Shaft(kg/m)
SFH		
SFH01205-2.8	0.11	0.87
SFH01210-2.8	0.144	0.87
SFH01605-3.8	0.184	1.37
SFH01610-2.8	0.212	1.37
SFH01616-1.8	0.208	1.37
SFH01616-2.8	0.26	1.37
SFH01620-1.8	0.24	1.37
SFH02005-3.8	0.246	2.45
SFH02010-3.8	0.336	2.45
SFH02020-1.8	0.332	2.45
SFH02020-2.8	0.442	2.45
SFH02505-3.8	0.27	3.83
SFH02510-3.8	0.384	3.83
SFH02525-1.8	0.43	3.83
SFH02525-2.8	0.576	3.83
SFH03205-3.8	0.65	6.29
SFH03210-3.8	0.65	5.89
SFH03220-2.8	0.8	5.89
SFH03232-1.8	0.84	5.89
SFH03232-2.8	1.114	5.89
SFH04005-3.8	0.808	9.84
SFH04010-3.8	1.026	8.82
SFH04020-2.8	1.282	8.82
SFH04040-1.8	1.518	8.82
SFH04040-2.8	2.158	8.82
SFH05005-3.8	1.098	15.39
SFH05010-3.8	1.458	14.12
SFH05020-3.8	2.172	14.12
SFH05050-1.8	2.486	14.12
SFH05050-2.8	3.524	14.12
SFA		
SFA01205-2.8	0.112	0.87
SFA01210-2.8	0.130	0.87
SFA01605-3.8	0.168	1.37
SFA01610-2.8	0.198	1.37
SFA01616-1.8	0.202	1.37
SFA01616-2.8	0.252	1.37
SFA01620-1.8	0.222	1.37
SFA01630-1.8	0.260	1.37
SFA02005-3.8	0.245	2.45
SFA02010-3.8	0.33	2.45
SFA02020-1.8	0.332	2.45
SFA02020-2.8	0.435	2.45
SFA02505-3.8	0.272	3.83
SFA02510-3.8	0.350	3.83

Model No.	Weight	
	Ball Nut(kg)	Screw Shaft(kg/m)
SFA02525-1.8	0.415	3.83
SFA02525-2.8	0.568	3.83
SFA03205-3.8	0.462	6.29
SFA03210-3.8	0.580	5.89
SFA03220-2.8	0.742	5.89
SFA03232-1.8	0.790	5.89
SFA03232-2.8	1.060	5.89
SFA04005-3.8	0.808	9.84
SFA04010-3.8	0.870	8.82
SFA04020-2.8	1.150	8.82
SFA04040-1.8	1.525	8.82
SFA04040-2.8	2.090	8.82
SFA05005-3.8	0.944	15.39
SFA05010-3.8	1.280	14.12
SFA05020-3.8	2.050	14.12
SFA05050-1.8	2.400	14.12
SFA05050-2.8	3.5	14.12
SFJ		
SFJ00606-1.8	0.019	0.2
SFJ00808-1.8	0.036	0.405
SFJ01205-2.8	0.09	0.87
SFJ01210-2.8	0.13	0.87
SFJ01605-3.8	0.15	1.37
SFJ01610-2.8	0.18	1.37
SFJ01616-1.8	0.178	1.37
SFJ01620-1.8	0.27	1.37
SFJ02005-3.8	0.201	2.45
SFJ02010-3.8	0.304	2.45
SFJ02020-1.8	0.306	2.45
SFJ02505-3.8	0.219	3.83
SFJ02510-3.8	0.355	3.83
SFJ02525-1.8	0.398	3.83
SCNH		
SCNH01205-4.8	0.092	0.87
SCNH01210-2.8	0.104	0.87
XCNH01210-1.8	0.08	0.87
SCNH01605-5.5	0.144	1.37
SCNH01610-2.8	0.14	1.37
SCNH01616-1.8	0.136	1.37
SCNH01620-1.8	0.17	1.37
SCNH02005-5.8	0.214	2.45
SCNH02010-3.8	0.254	2.45
SCNH02020-1.8	0.252	2.45
SFNU		
SFNU01605-4	0.19	1.56
SFNU01610-3	0.22	1.56

TBI MOTION BALL SCREW

2-5 Ball Screw Weight List

C
Ball Screw

Model No.	Weight	
	Ball Nut(kg)	Screw Shaft(kg/m)
SFNU02005-4	0.316	2.45
SFNU02505-4	0.35	3.83
SFNU02510-4	0.484	3.81
SFNU03205-4	0.588	6.29
SFNU03210-4	0.832	6.23
SFNU04005-4	0.97	9.84
SFNU04010-4	1.246	9.78
SFNU05010-4	1.82	15.33
SFNU05020-4	2.674	15.31
SFNU06310-4	2.576	24.39
SFNU06320-4	4.888	24.28
SFNU08010-4	3.1	39.38
SFNU08020-4	9.016	39.27
SFU		
SFU01204-4	0.138	0.87
SFU01604-4	0.184	1.57
SFU02004-4	0.294	2.45
SFU02504-4	0.384	3.84
SFU02506-4	0.356	3.82
SFU02508-4	0.41	3.81
SFU03204-4	0.658	6.30
SFU03206-4	0.66	6.28
SFU03208-4	0.744	6.27
SFU04006-4	1.076	9.83
SFU04008-4	1.200	9.82
SFU10020-4	10	61.47
OFU		
OFU01605-4	0.27	1.56
OFU02005-4	0.512	2.45
OFU02505-4	0.532	3.83
OFU02510-4	0.808	3.81
OFU03205-4	0.946	6.29
OFU03210-4	1.278	6.23
OFU04005-4	1.486	9.84
OFU04010-4	2.18	9.78
OFU05010-4	3.052	15.33
OFU06310-4	4.175	24.39
OFU08010-4	4.806	39.38
SFNI		
SFNI01605-4	0.22	1.56
SFNI01610-3	0.382	1.56
SFNI02005-4	0.308	2.45
SFNI02505-4	0.396	3.83
SFNI02510-4	0.802	3.81
SFNI03205-4	0.472	6.29
SFNI03210-4	1.14	6.23

Model No.	Weight	
	Ball Nut(kg)	Screw Shaft(kg/m)
SFI		
SFI01604-4	0.246	1.57
SFI02004-4	0.312	2.45
SFI0205T-4	0.332	2.45
SFI02504-4	0.386	3.84
SFI0255T-4	0.398	3.83
SFI03204-4	0.46	6.30
OFI		
OFI01605-4	0.318	1.56
OFI02005-4	0.44	2.45
OFI02505-4	0.57	3.83
OFI02510-4	1.348	3.81
OFI03205-4	0.686	6.29
OFI03210-4	1.796	6.23
OFI04005-4	1.184	9.84
OFI04010-4	2.326	9.78
OFI05010-4	2.84	15.33
OFI06310-4	3.835	24.39
OFI08010-4	5.080	39.38
SFM		
SFM03205-4	0.552	6.29
SFM0320T-4	0.562	6.29
SFV		
SFV01205-2.8	0.254	0.87
SFV01210-2.7	0.304	0.87
SFV01510-2.7	0.350	1.37
SFV01604-3.8	0.500	1.57
SFV01605-4.8	0.556	1.56
SFV01610-2.7	0.532	1.56
SFV02004-4.8	0.650	2.45
SFV02005-4.8	0.62	2.45
SFV02010-2.7	0.67	2.43
SFV02020-1.8	0.700	2.45
SFV02505-4.8	0.722	3.83
SFV02506-4.8	0.672	3.82
SFV02508-4.8	1.880	3.81
SFV02510-2.7	1.944	3.77
SFV02525-1.8	0.850	3.83
SFV03204-4.8	0.850	6.30
SFV03205-4.8	0.962	6.29
SFV03206-4.8	0.950	6.28
SFV03208-4.8	1.500	6.27
SFV03210-4.8	2.816	6.23
SFV03220-2.7	2.908	6.23
SFV04005-4.8	1.429	9.84
SFV04010-4.8	3.61	9.78

Model No.	Weight	
	Ball Nut(kg)	Screw Shaft(kg/m)
SFV04020-2.7	3.58	9.78
SFV05005-4.8	1.836	15.39
SFV05010-4.8	3.944	15.33
SFV05020-2.7	7.306	15.23
SFV06310-4.8	5.858	24.39
SFV06320-2.7	9.43	24.28
SFV08010-4.8	7.856	39.38
SFV08020-4.8	17.05	39.27
SFV08020-7.6	21.478	39.27
OFV		
OFV01605-4.8	0.800	1.56
OFV02005-4.8	1.066	2.45
OFV02505-4.8	1.212	3.83
OFV03205-4.8	1.572	6.29
OFV03210-4.8	4.978	6.23
OFV04005-4.8	2.226	9.84
OFV04010-4.8	6.084	9.78
OFV05010-4.8	6.560	15.33
OFV06310-4.8	9.606	24.39
OFV08010-4.8	12.890	39.38
SFY		
SFY01616-3.6	0.238	1.55
SFY01616-5.6	0.31	1.55
SFY01632-1.6	0.222	1.55
SFY01632-3.6	0.36	1.55
SFY02020-3.6	0.38	2.42
SFY02020-5.6	0.506	2.42
SFY02040-1.6	0.348	2.42
SFY02040-3.6	0.604	2.42
SFY02525-3.6	0.652	3.79
SFY02525-5.6	0.884	3.79
SFY02550-1.6	0.596	3.79
SFY02550-3.6	1.056	3.79
SFY03232-3.6	1.168	6.22
SFY03232-5.6	1.598	6.22
SFY03264-1.6	1.066	6.22
SFY03264-3.6	2.006	6.22
SFY04040-3.6	2.288	9.70
SFY04040-5.6	3.24	9.70
SFY04080-1.6	2.096	9.70
SFY04080-3.6	3.902	9.70
SFY05050-3.6	4.12	15.15
SFY05050-5.6	5.762	15.15
SFY50100-1.6	3.818	15.15
SFY50100-3.6	7.12	15.15
SFYA		

Model No.	Weight	
	Ball Nut(kg)	Screw Shaft(kg/m)
SFYA01616-3.6	0.21	1.37
SFYA01632-1.6	0.2	1.37
SFYA02020-3.6	0.36	2.45
SFYA02040-1.6	0.33	2.45
SFYA02525-3.6	0.61	3.83
SFYA02550-1.6	0.57	3.83
SFYA03232-3.6	1.09	5.89
SFYA03264-1.6	1	5.89
SFYA04040-3.6	2.18	8.82
SFYA04080-1.6	2.01	8.82
SFYA05050-3.6	3.79	14.12
SFYA050100-1.6	3.61	14.12
SCNI		
SCNI01605-4	0.146	1.56
SCNI02005-4	0.17	2.45
SCNI02505-4	0.226	3.83
SCNI02510-4	0.664	3.81
SCNI03205-4	0.252	6.29
SCNI03210-4	0.784	6.23
SCNI04005-4	0.406	9.84
SCNI04010-4	0.932	9.78
SCNI05010-4	1.21	15.33
SCNI06310-4	1.52	24.39
SCNI08010-4	2.292	39.38
SCI01604-4	0.142	1.57
SCI02004-4	0.160	2.45
SCI02504-4	0.220	3.84
SCI03204-4	0.200	6.30
SFK		
SFK00401	0.024	0.1
SFK00601	0.014	0.22
SFK00801	0.018	0.39
SFK00802	0.019	0.39
SFK0082.5	0.034	0.39
SFK01002	0.046	0.61
SFK01004	0.055	0.61
SFK01202	0.05	0.88
SFK01205	0.08	0.87
SFK01402	0.05	1.21
SFK01404	0.116	1.2
SFK01602	0.116	1.58
SFK02002	1	2.46
SFK02502	0.38	3.85
XSFK01004	0.146	0.61

TBI MOTION BALL SCREW

2-5 Ball Screw Weight List

Model No.	Weight	
	Ball Nut(kg)	Screw Shaft(kg/m)
XSFK01404	0.121	1.2
XSU		
XSU01204T3D-02	0.092	0.87
BSHR		
BSHR0082.5-2.5	0.033	0.39
BSHR01002-3.5	0.036	0.61
BSHR01004-2.5	0.088	0.61
BSHR01204-3.5	0.086	0.87
BSHR01205-3.5	0.102	0.87
BSHR01404-3	0.144	1.20
BSHR01604-3	0.112	1.57
BSHR01605-3	0.146	1.56
BSHR01610-2	0.180	1.56
BSHR02005-3	0.22	2.45
BSHR02505-4	0.388	3.83
BSHR02510-4	0.494	3.81
XSV		
XSV01210-01	0.27	0.87
XSV01510-00	0.332	1.37
XSV01520-01	0.348	1.37
XSV02010-00	0.632	2.43
XSV02020-00	0.758	0.39
XSY		
XSY01220A2D-00	0.132	0.87